

STAPLE



basic education

Department:
Basic Education
REPUBLIC OF SOUTH AFRICA

**NATIONAL
SENIOR CERTIFICATE**

GRADE 12

ENGINEERING GRAPHICS AND DESIGN P2
FEBRUARY/MARCH 2015

MARKS: 100

TIME: 3 hours

This question paper consists of 6 pages.



INSTRUCTIONS AND INFORMATION

1. This question paper consists of FOUR questions.
2. Answer ALL the questions.
3. ALL drawings are in third-angle orthographic projection, unless otherwise stated.
4. ALL drawings must be completed using instruments, unless otherwise stated.
5. ALL answers must be drawn accurately and neatly.
6. ALL the questions must be answered on the QUESTION PAPER as instructed.
7. ALL the pages must be re-stapled in numerical sequence, irrespective of whether the question was attempted.
8. Time management is essential in order to complete all the questions.
9. Print your examination number in the block provided on every page.
10. Any details or dimensions not given must be assumed in good proportion.

FOR OFFICIAL USE ONLY										
QUESTION	MARKS OBTAINED			½	SIGN	MODERATED			½	SIGN
1										
2										
3										
4										
TOTAL										
	2	0	0			2	0	0		

FINAL CONVERTED MARK	CHECKED BY
100	

COMPLETE THE FOLLOWING:
CENTRE NUMBER
CENTRE NUMBER
EXAMINATION NUMBER
EXAMINATION NUMBER

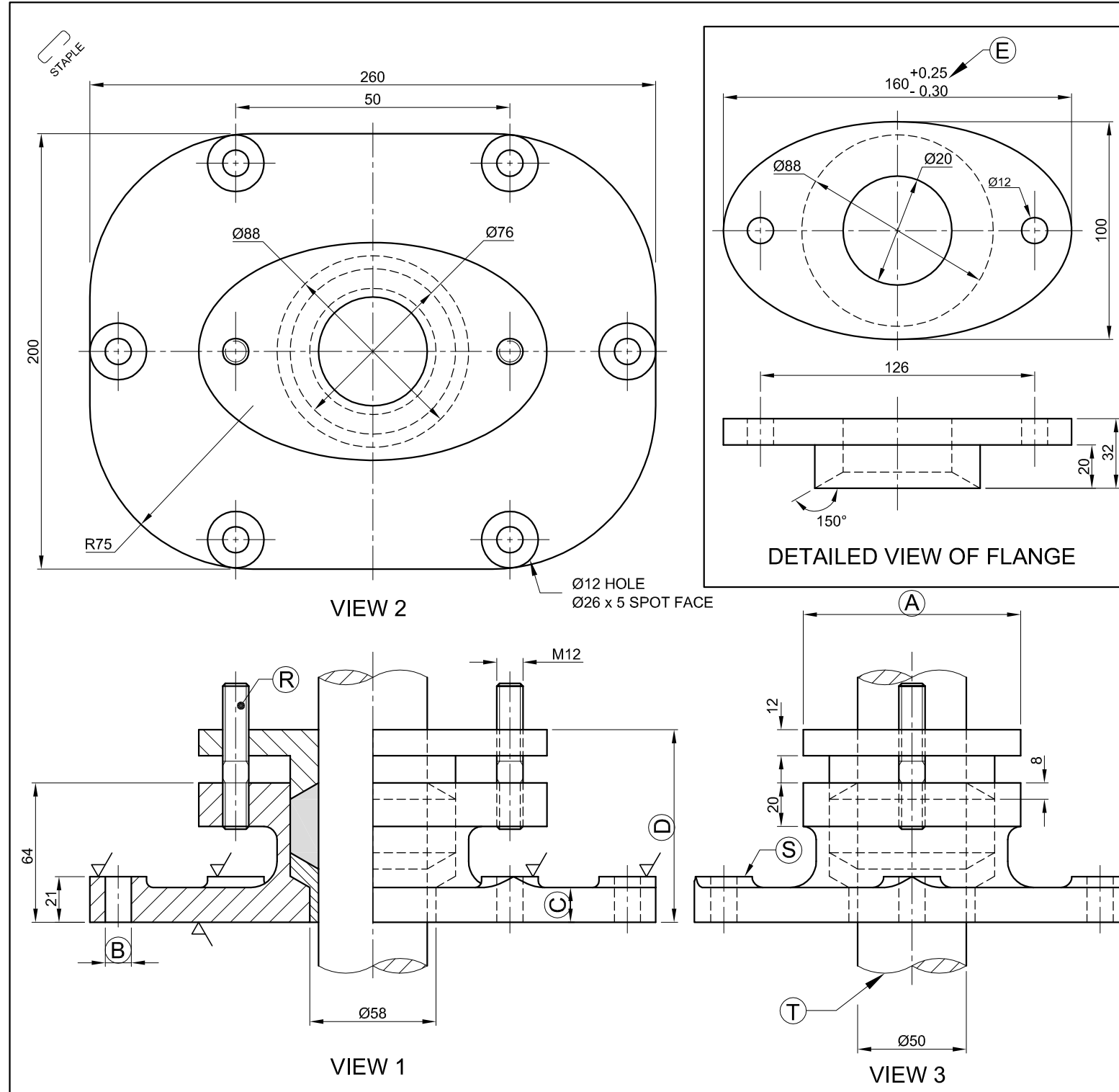

QUESTION 1: ANALYTICAL (MECHANICAL)

Given:

A front view, top view and right view of a box and gland assembly, detailed drawing of the flange, a title block and a table of questions. The drawings have not been prepared to the indicated scale.

Instructions:

Complete the table below by neatly answering the questions, which all refer to the accompanying drawings and the title block. [30]

QUESTIONS		ANSWERS	
1	On what date was the drawing approved?	1	
2	What is the title of the assembly?	1	
3	What scale is indicated for the drawing?	1	
4	What material is used to manufacture the bush?	1	
5	On what date was the revision done?	1	
6	What is the drawing number?	1	
7	What would VIEW 3 be called?	1	
8	What type of section is shown in VIEW 1?	1	
9	What part is used to protect the flange surface when the nut is being tightened?	1	
10	Name the part at R.	1	
11	Name the feature at S.	1	
12	Name the feature at T.	1	
13	How many surfaces need to be machined?	1	
14	Give the complete dimensions at: A B	2	
15	Determine the complete dimensions at: C D	4	
16	With reference to the tolerance, determine the maximum dimension at E.	2	
17	With reference to the tolerance, determine the minimum dimension at E.	2	
18	Insert the cutting plane on VIEW 3 and label it A-A.	3	
19	In the space provided below, draw, in neat freehand, the symbol for the projection system used.	4	
TOTAL		30	

ALL DIMENSIONS ARE IN MILLIMETRES	SCALE: 1 : 2
DRAWING PROGRAM: AUTOCAD 2013	FINISH: POLISHED
FILE NAME: ANAS15.dwg	QUANTITY: 325 UNITS
DRAWING No. BG-15/4	MACHINING: MILLING

UNLESS OTHERWISE SPECIFIED, ALL TOLERANCES ON DIMENSIONS ARE ± 0,15. ALL UNSPECIFIED RADII ARE R3.

PEWIJO ENGINEERING	15 FABRICIA ROAD KLISSERVILLE KIMBERLEY 8301 051 6273 849
	TITLE BOX AND GLAND

REVISIONS	DATE
2.	
1. INSERT SPOT FACE	2014/02/03
DRAWN: ALFA	2014/01/01
CHECKED: BRAVO	2014/02/02
APPROVED: ZERO	2014/03/03

PARTS LIST		
PART	MATERIAL	QUANTITY
1 BASE	CAST IRON	1
2 FLANGE	MILD STEEL	1
3 STUD	MILD STEEL	2
4 SHAFT	HARDENED STEEL	1
5 BUSH	RUBBER	1
6 WASHER	MILD STEEL	2
7 NUT	MILD STEEL	2

ANSWER 19

SYMBOL

EXAMINATION NUMBER	
EXAMINATION NUMBER	2





QUESTION 2: LOCI

HELIX

Given:

- The left view of a square spring with RS indicating starting position
- The position of centre point T on the drawing sheet

Specifications:

- Pitch = 72
- Spring profile = 24 x 24
- Direction = Right-handed

Instructions:

Draw, to scale 1 : 1, the following:

- 2.1 The given left view with point T as reference
- 2.2 The front view for TWO turns of the square spring

- Show ALL necessary construction.
- No hidden detail is required.

[37]

T

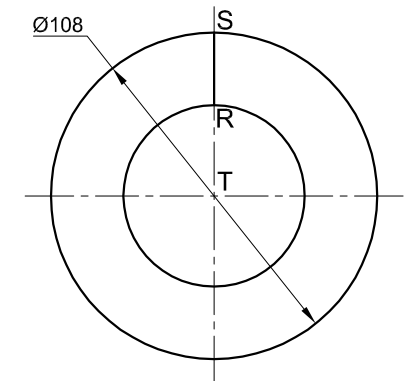

ASSESSMENT CRITERIA				
1	GIVEN + CENTRE LINES + STARTING POINT	4 ½		
2	CONSTRUCTION	8		
3	OUTSIDE POINTS + CURVE + QUALITY	14 ½		
4	INSIDE POINTS + CURVE + QUALITY	10		
PENALTIES (-)				
TOTAL		37		
EXAMINATION NUMBER				
EXAMINATION NUMBER				
EXAMINATION NUMBER				3





QUESTION 3: ISOMETRIC DRAWING

Given:

- The front view, top view and left view of a machine switch with cutting plane A-A
- The position of point P on the drawing sheet

Instructions:

Using scale 1 : 1, convert the orthographic views of the machine switch into a sectional isometric drawing on cutting plane A-A.

- Make P the lowest point of the drawing.
- Show ALL necessary construction.
- NO hidden detail is required.

[39]

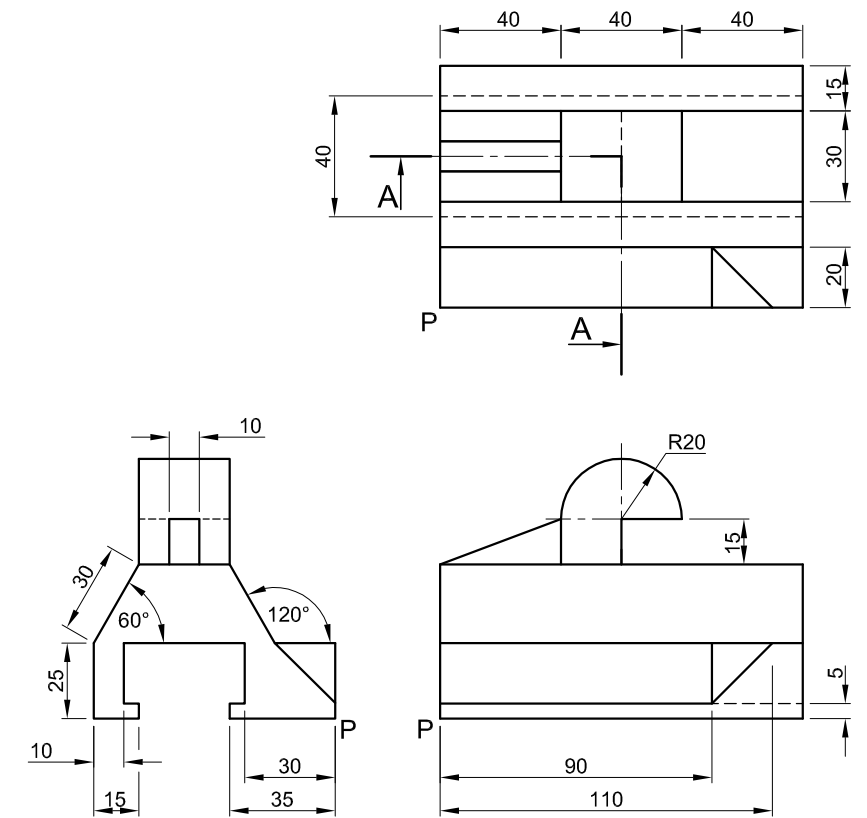

P ↓

ASSESSMENT CRITERIA				
1	AUX. VIEW + PLACING	3		
2	ISOMETRIC + NON-ISOMETRIC LINES	16½		
3	ISO' CIRCLES + CIRCLE CONSTRUCTION	5		
4	SECTIONED SURFACES	11		
5	HATCHING	3½		
PENALTIES (-)				
TOTAL		39		
EXAMINATION NUMBER				
EXAMINATION NUMBER				
EXAMINATION NUMBER				4



STAPLE

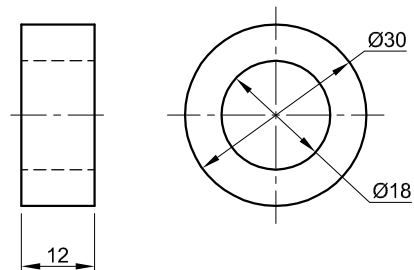

SEAL [2]

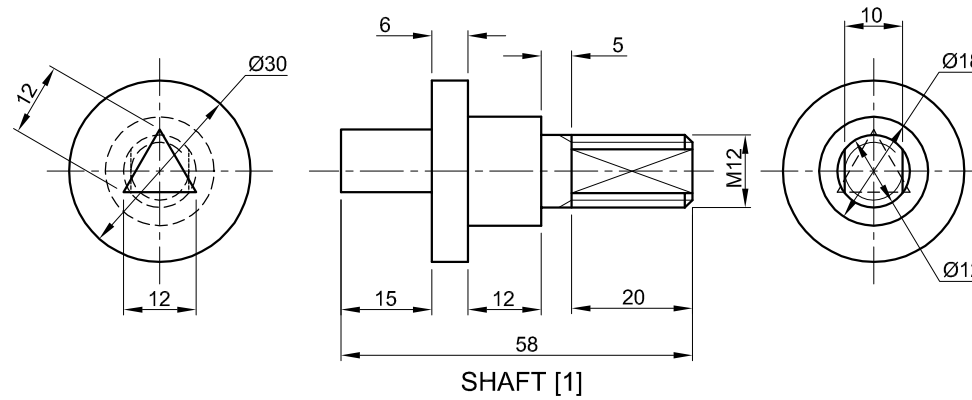

SHAFT [1]

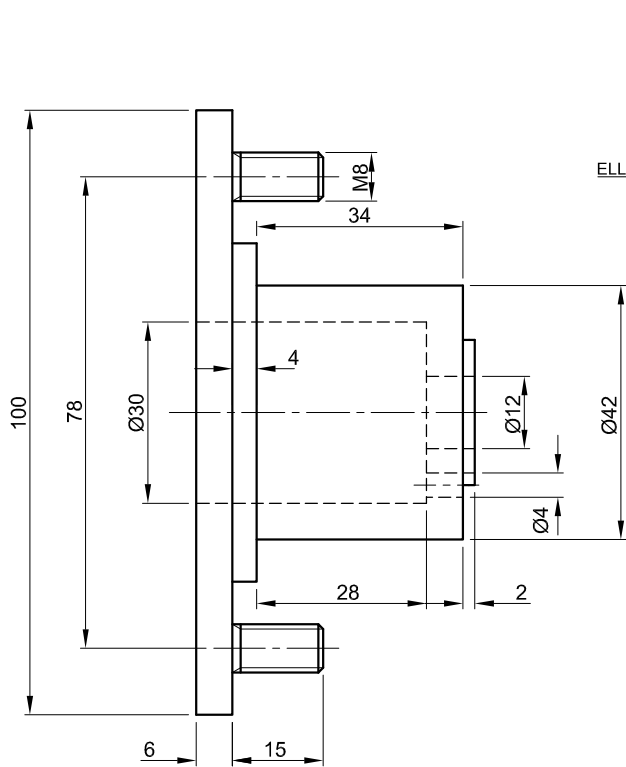

BASE [3]

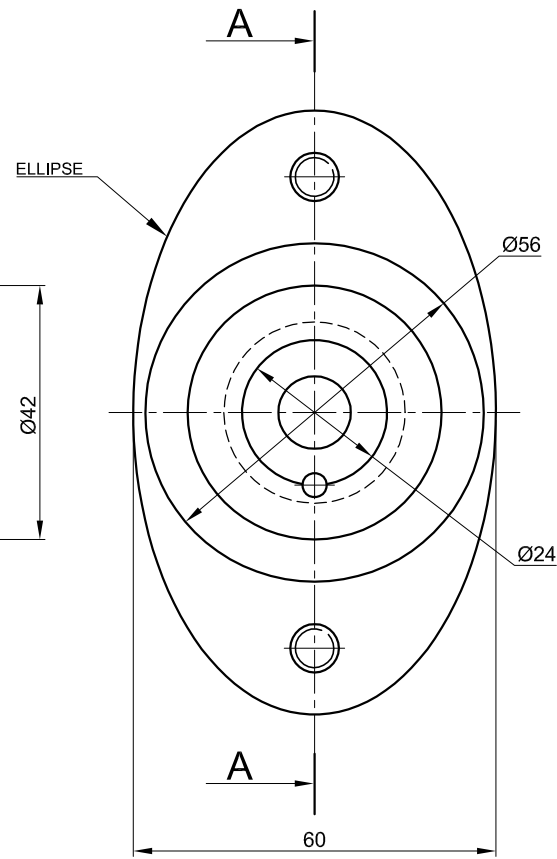

LOCKING LEVER [5]

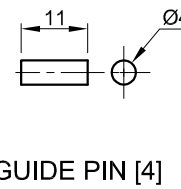

GUIDE PIN [4]

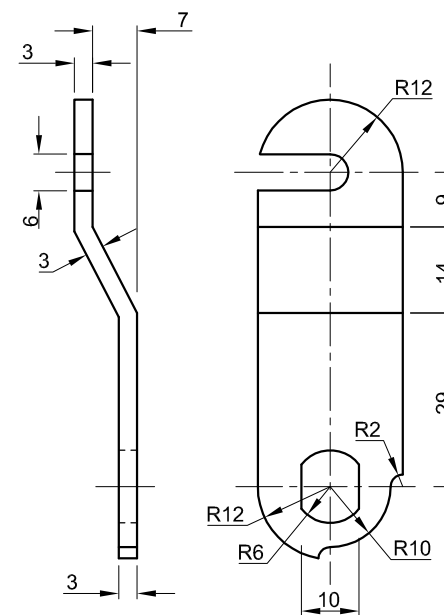

M12 NUT [7]

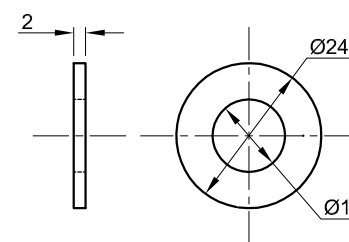

WASHER [6]

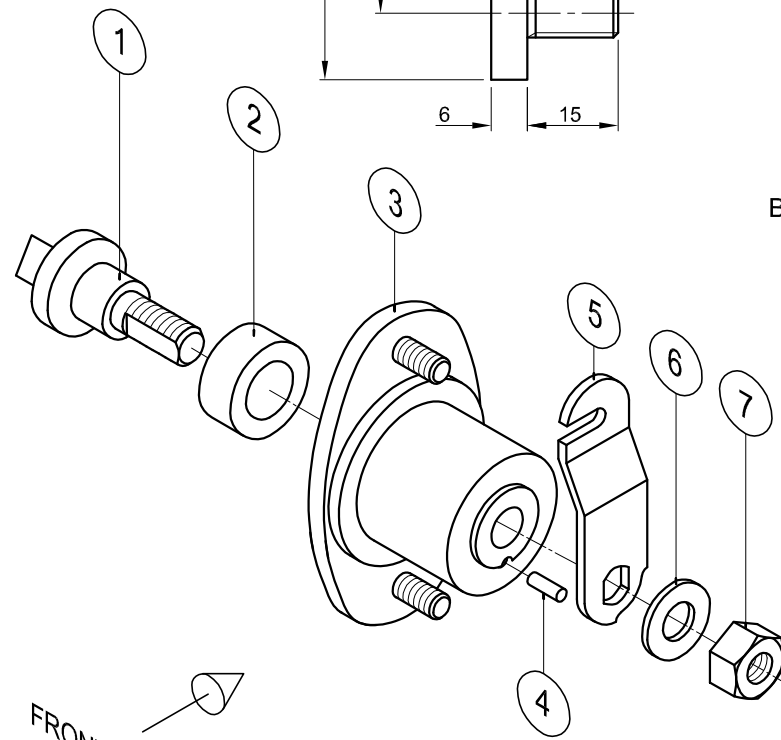

EXPLODED ISOMETRIC DRAWING

QUESTION 4: MECHANICAL ASSEMBLY

Given:

- The exploded isometric drawing of the parts of a distribution box lock assembly, showing the position of each part relative to all the others
- Orthographic views of each of the parts of the distribution box lock assembly

Instructions:

- Answer this question on page 6.
- Draw, to scale 2 : 1 and in third-angle orthographic projection, the following views of the assembled parts of the distribution box lock assembly:

4.1 A sectional front view on cutting plane A-A, as seen from the direction of the arrow shown on the exploded isometric drawing. The cutting plane, which passes vertically through the centre of the assembly, is shown on the right view of the base (part 3).

4.2 The right view

- ALL drawing must comply with the guidelines contained in the SANS 10111.

NOTE:

- Show THREE faces and ALL necessary construction of the M12 nut.
- Show ALL necessary construction of the ellipse.
- Show ALL necessary construction of the triangle.
- Add cutting plane A-A to the drawing.
- NO hidden detail is required.

[94]

PARTS LIST		
PART	QUANTITY	MATERIAL
1	1	SHAFT STAINLESS STEEL
2	1	SEAL RUBBER
3	1	BASE CAST IRON
4	1	GUIDE PIN MILD STEEL
5	1	LOCKING LEVER MILD STEEL
6	1	WASHER MILD STEEL
7	1	M12 NUT MILD STEEL

JPW ENGINEERING CC
 123 STRUBEN STREET
 PRETORIA
 0001
 www.jpwengineering.co.za
 012 345 6789

DISTRIBUTION BOX LOCK

ALL DIMENSIONS ARE IN MILLIMETRES

ALL UNSPECIFIED RADII ARE R3.

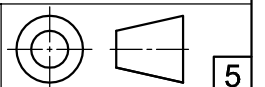



PENALTIES		
NOT IN THIRD ANGLE		
INCORRECT OVERALL SCALE		
INCORRECT HATCHING		
TOTAL PENALTIES (-)		

ASSESSMENT CRITERIA					
SECTIONAL FRONT VIEW					
		POSSIBLE	OBTAINED	SIGN	MODERATED
1	SHAFT	17 $\frac{1}{2}$			
2	SEAL	2			
3	BASE	18 $\frac{1}{2}$			
4	GUIDE PIN	2 $\frac{1}{2}$			
5	LOCKING LEVER	7			
6	WASHER	2 $\frac{1}{2}$			
7	M12 NUT	6 $\frac{1}{2}$			
	SUBTOTAL	56 $\frac{1}{2}$			
RIGHT VIEW					
1	SHAFT	5			
2	M12 NUT	4			
3	WASHER	1			
4	LOCKING LEVER	4 $\frac{1}{2}$			
5	BASE	9			
6	GUIDE PIN	1			
7	CUTTING PLANE	3			
	SUBTOTAL	27 $\frac{1}{2}$			
GENERAL					
1	CENTRE LINES	4			
2	ASSEMBLY	6			
	SUBTOTAL	10			
	TOTAL	94			
	TOTAL PENALTIES (-)				
	FINAL TOTAL				
EXAMINATION NUMBER					
EXAMINATION NUMBER					
					6

