



basic education

Department:
Basic Education
REPUBLIC OF SOUTH AFRICA

**NATIONAL
SENIOR CERTIFICATE**

GRADE 12

**AGRT.1
AGRICULTURAL TECHNOLOGY
NOVEMBER 2014**

MARKS: 200

TIME: 3 hours

This question paper consists of 15 pages.

MORNING SESSION



INSTRUCTIONS AND INFORMATION

1. GENERAL INSTRUCTIONS AND INFORMATION
 - 1.1 This question paper consists of TWO sections, namely SECTION A and SECTION B.
 - 1.2 BOTH sections are COMPULSORY.
 - 1.3 Answer ALL the questions in the ANSWER BOOK.
 - 1.4 Number the answers correctly according to the numbering system used in this question paper.
 - 1.5 Non-programmable calculators may be used.
 - 1.6 Write neatly and legibly.
2. SECTION A: SHORT QUESTIONS
 - 2.1 This section consists of THREE questions.
 - 2.2 Follow the instructions when answering the questions.
3. SECTION B: STRUCTURED LONG QUESTIONS
 - 3.1 This section consists of FIVE questions.
 - 3.2 Start EACH question on a NEW page.



SECTION A**QUESTION 1**

- 1.1 Various options are provided as possible answers to the following questions. Choose the answer and write only the letter (A–D) next to the question number (1.1.1–1.1.10) in the ANSWER BOOK, for example 1.1.11 B.
- 1.1.1 Three practical and effective steps can be followed to control health hazards in the workplace. You must first spot a potential hazard, then assess or identify the risk and finally you must ...
- A run away.
 - B call the fire department.
 - C decide what to do.
 - D make changes to eliminate or control the hazard. (2)
- 1.1.2 According to the ... a tractor seat must be fitted with a seatbelt approved by the South African Bureau of Standards (SABS).
- A Occupational Health and Safety Act, 1993 (Act 85 of 1993)
 - B Compensation for Occupational Injuries and Diseases Act, 1993 (Act 130 of 1993)
 - C Labour Relations Act, 1995 (Act 66 of 1995)
 - D Basic Conditions of Employment Act, 1997 (Act 75 of 1997) (2)
- 1.1.3 Tractor rollover is often caused by ...
- A overloading a tractor trailer.
 - B using the power take-off when turning.
 - C a front-end loader carrying a load too high.
 - D a punctured tyre. (2)
- 1.1.4 In order to prevent an accident with a power take-off shaft the operator should ...
- A activate the sensitivity element.
 - B stop the power take-off before dismounting from the tractor.
 - C walk around the tractor.
 - D climb over the power take-off shaft to keep spectators away. (2)
- 1.1.5 The main line of the centre-pivot irrigation system consists of several pipe segments, usually made of ...
- A galvanised steel.
 - B mild steel.
 - C copper and brass.
 - D brass and mild steel. (2)



- 1.1.6 Which ONE of the following is NOT a work design (ergonomic) hazard?
- A Lifting of heavy objects
 - B Electrical currents
 - C Moving of heavy objects
 - D Repositioning of heavy loads
- (2)
- 1.1.7 Which ONE of the following is NOT applicable to the prevention of noise-induced hearing loss?
- A Protect your worker's hearing by reducing or controlling noise at its source.
 - B Consider the long-term benefits of obtaining suitable, silent equipment.
 - C Open your mouth when hammering with a five-pound hammer.
 - D Use mufflers or silencers on motors, air hoses and other equipment.
- (2)
- 1.1.8 The ... valve should be opened first when you want to ignite an oxyacetylene flame.
- A oxygen
 - B argon
 - C acetylene
 - D carbon dioxide
- (2)
- 1.1.9 The output voltage of a plasma cutter should always be ... for effective cutting to take place.
- A 10–30 volts
 - B 15–20 volts
 - C 20–50 volts
 - D 50–100 volts
- (2)
- 1.1.10 In a geothermal power station, heat from deep within the earth heats water that provides energy to generate electricity. This method of producing energy can cause ...
- A slight air pollution.
 - B serious weather changes.
 - C extensive water shortages.
 - D excessive noise pollution.
- (2)



1.2 Change the UNDERLINED word(s) in each of the following statements to make the statements TRUE. Write only the answer next to the question number (1.2.1–1.2.5) in the ANSWER BOOK, for example 1.2.6 Tractor.

- 1.2.1 A gas regulator controls the flow of water in one direction in an irrigation system. (2)
- 1.2.2 Steel coated with resin must preferably not be welded with the MIG welding machine because it gives off poisonous gas. (2)
- 1.2.3 Three-phase electricity have an average voltage of 220–240 volts. (2)
- 1.2.4 Biodiesel is manufactured from maize. (2)
- 1.2.5 The carbon dioxide fire extinguisher is the most versatile extinguisher to use in a farm workshop. (2)

1.3 Choose a word/term from COLUMN B that matches the description in COLUMN A. Write only the letter (A–G) next to the question number (1.3.1–1.3.5) in the ANSWER BOOK, for example 1.3.6 H.

COLUMN A		COLUMN B	
1.3.1	Mainly used for bearings and does not seize and swell on shafts	A	biofuel
		B	Teflon
1.3.2	An alternative fuel made from vegetable oil	C	grease
		D	resin
1.3.3	A product of distilling starch and sugar crops	E	tin and lead
1.3.4	A synthetic material that is not influenced by heat and acids	F	Vesconite
		G	ethanol
1.3.5	Low viscosity fluids that can be transformed into a tough, flexible solid by adding a hardening agent		

(5 x 2) (10)

TOTAL SECTION A: 40



SECTION B**QUESTION 2: MATERIALS AND STRUCTURES**

Start this question on a NEW page.

- 2.1 THREE main alloy elements are added to stainless steel to give different properties for different applications.
- 2.1.1 Name the THREE main alloy elements found in stainless steel. (3)
- 2.1.2 State TWO influences of EACH of these three alloy elements on stainless steel in QUESTION 2.1.1. (6)
- 2.2 State the precautionary measure a farmer needs to take to prevent cracks and brittleness when soldering brass. (2)
- 2.3 State THREE applications of bronze products on a farm. (3)
- 2.4 Name TWO properties of copper as used in the starter motor of a tractor. (2)
- 2.5 A farm manager needs to place safety posters against the wall of the farm workshop. The adhesive used for this purpose must stick for a long time.
- 2.5.1 Name an adhesive that can be used to stick the posters to the wall. (1)
- 2.5.2 Explain the difference between *cohesion* and *adhesion* as properties of an adhesive. (4)
- 2.6 A branch from a tree fell on the fibre-glass canopy of your tractor and you want to repair the damage yourself. State THREE precautionary measures to be taken when working with fibre-glass. (3)
- 2.7 Electric fencing is a very popular, versatile and effective form of fencing and can be used in both temporary and permanent fences.
- 2.7.1 State FIVE safety regulations applicable to electric fences. (5)
- 2.7.2 Describe ways of increasing the earthing efficiency of an electric fence constructed on poor earth conditions. (3)
- 2.7.3 State the main purpose of the conductor wire of an electric fence. (2)
- 2.7.4 Name a type of wire that may NOT be electrified. (1)
- [35]**



QUESTION 3: ENERGY

Start this question on a NEW page.

- 3.1 Name a type of solar system, other than photovoltaic panels, that can be used to heat water in a dairy. (1)
- 3.2 Study the photograph below of a solar system and answer the questions that follow.



- 3.2.1 State THREE factors that can influence the efficiency of the solar panels in the photograph above. (3)
- 3.2.2 Is it possible to store the energy generated by the solar panel during the day for use at night? (1)
- 3.2.3 Motivate your answer to QUESTION 3.2.2. (1)
- 3.2.4 Name the device that can be used to change direct current to alternating current. (1)

- 3.3 Briefly describe the way in which the structure below generates electrical energy from the wind energy.



- (4)
- 3.4 Methanol as an alternative fuel can be obtained from different products. Name TWO of these products. (2)
- 3.5 Geothermal energy is one of the most underutilised renewable energy sources on Earth.
- 3.5.1 Name TWO advantages of geothermal energy. (2)
- 3.5.2 State ONE instance where the use of geothermal energy can pollute the environment. (1)
- 3.5.3 Describe the consequences if too much cold water is pumped into the geothermal heat source. (2)
- 3.6 Name TWO disadvantages of wind as an alternative energy source. (2)
- [20]**

QUESTION 4: SKILLS AND CONSTRUCTION PROCESSES

Start this question on a NEW page.

4.1 The illustration below shows all the components of a MIG welding machine commonly used in a workshop.

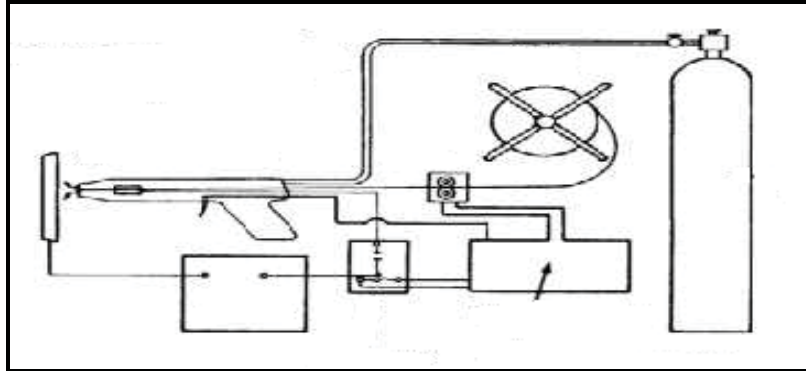

4.1.1 The MIG welding machine has certain limitations that force most operators to use an arc-welding machine. Name THREE of these limitations. (3)

4.1.2 State FOUR causes of porosity in welding joints while doing MIG welding. (4)

4.1.3 Zigzag welding is a commonly used welding run figure in vertical welding. Name and draw THREE other welding run figures that can be used in arc welding. (6)

4.2 A plasma cutting machine (A) and an oxyacetylene welding set (B) are shown below. Answer the questions that follow.

A



B

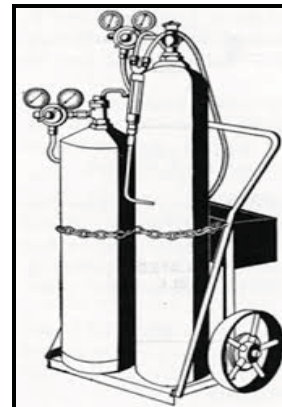

4.2.1 Explain why a farmer will prefer a plasma cutting machine instead of an oxyacetylene cutting torch for cutting steel less than 25 mm thick. (3)

4.2.2 Various gasses are available for plasma cutting. Name TWO of these gasses and give ONE application of each. (4)



4.3 Personal body protection worn by people working in a workshop is an important safety precaution. Name FOUR categories of personal body protection. (4)

4.4 **SCENARIO**
The manager of a dairy farm needs a small gate to control the movement of cows as they enter the milking parlour. You have been asked to design the gate. The width of the passage where the gate must be installed is 800 mm and the height of the gate must be 1 000 mm. The material available to build the gate is Ø25 mm pipe and 25 mm x 6 mm flat bar.

Make a freehand sketch of the gate with TWO hinges and a lock mechanism.

Marks will be allocated for:

- Proportional drawing (2)
- Practical applicability (2)
- TWO hinges (1)
- ONE lock mechanism (1)
- THREE measurements (1)
- Cutting list of materials to be used (2) (9)

4.5 The photograph below shows an oxyacetylene cutting torch. Identify parts **A** and **B**.

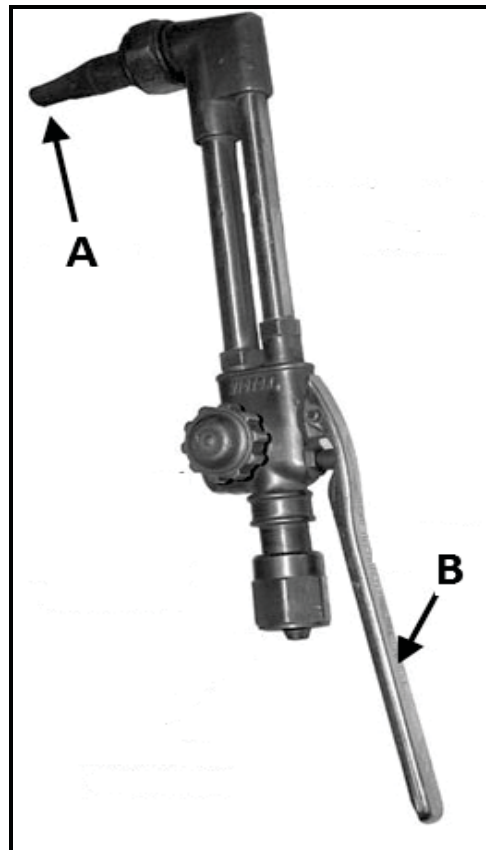

(2)
[35]



QUESTION 5: TOOLS, IMPLEMENTS AND EQUIPMENT

Start this question on a NEW page.

5.1 Study the photograph below and answer the questions that follow.



5.1.1 Name the device in the above picture. (1)

5.1.2 State the main function of this device. (1)

5.2 The pictures below show the different types of gears found in gearboxes.

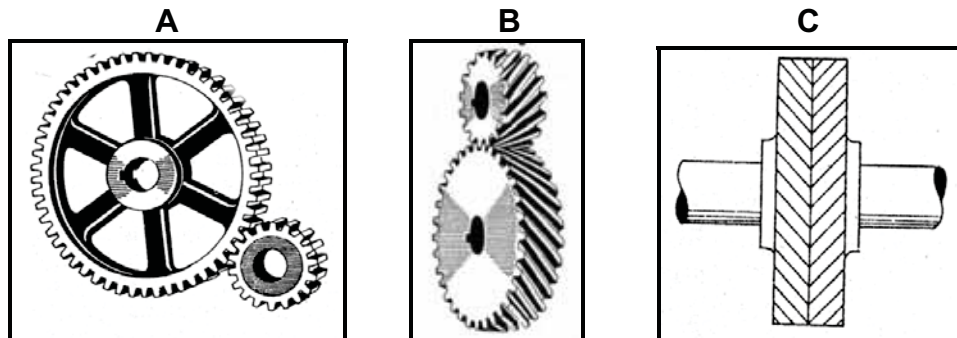

Name gears **A**, **B** and **C** as shown in the pictures above. (3)

5.3 Two gears that are meshed have a gear ratio of 1 : 3 (drive gear : driven gear). Calculate the number of teeth on the driven gear if the drive gear has 60 teeth. Show ALL calculations.

Use the following formula:
$$\text{Gear ratio} = \frac{\text{drive gear}}{\text{driven gear}}$$
 (4)

5.4 Name a safety mechanism that can be installed in farm implements to protect components. (1)

5.5 Study the sketch below and answer the questions that follow.

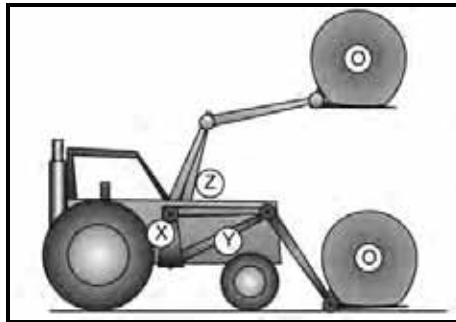

5.5.1 Give the main reason for side overturns when using this machine. (1)

5.5.2 Name THREE precautionary measures that must be taken to prevent a worker from being crushed while lifting bales with a front-end loader. (3)

5.6 The sketches below show two different methods of hitching a trailer to a tractor.

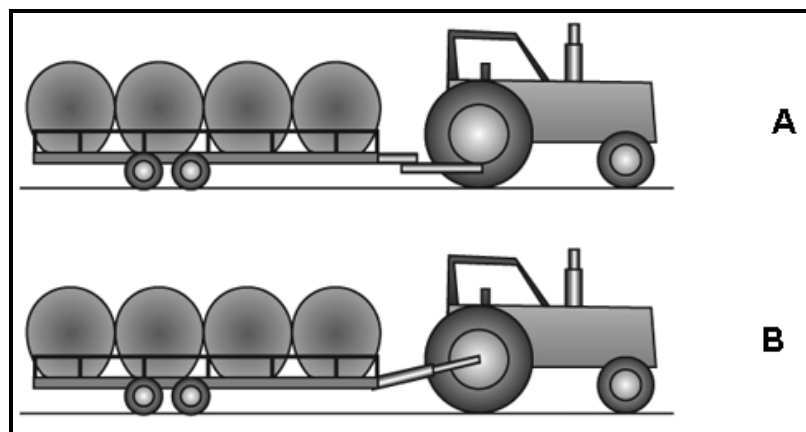

5.6.1 Choose the correct hitching method (**A** or **B**). (1)

5.6.2 Motivate your answer to QUESTION 5.6.1. (2)

5.6.3 Explain why a tractor should be placed in a low gear before going downhill when pulling a loaded trailer. (1)

5.6.4 Explain why hay bales should never be allowed to touch the tyres of a trailer while it is being transported. (1)

5.6.5 Certain safety precautions must be followed every time a trailer is hitched. Name THREE such safety precautions. (3)

- 5.7 The sketch below shows a double-action hydraulic cylinder as used in the hydraulic system of a tractor.

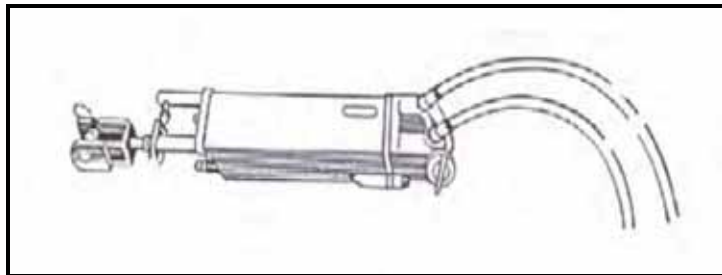

- 5.7.1 Describe the working of the double-action hydraulic cylinder. (4)
- 5.7.2 Name THREE advantages of transmission oil that is used in hydraulic systems in tractors. (3)
- 5.7.3 Which side of the double-action hydraulic cylinder (the side with the shaft or the side without the shaft) is the strongest? (1)
- 5.7.4 Motivate your answer to QUESTION 5.7.3. (1)
- 5.8 The sketch below shows the different components of the clutch of a tractor. Answer the questions that follow.

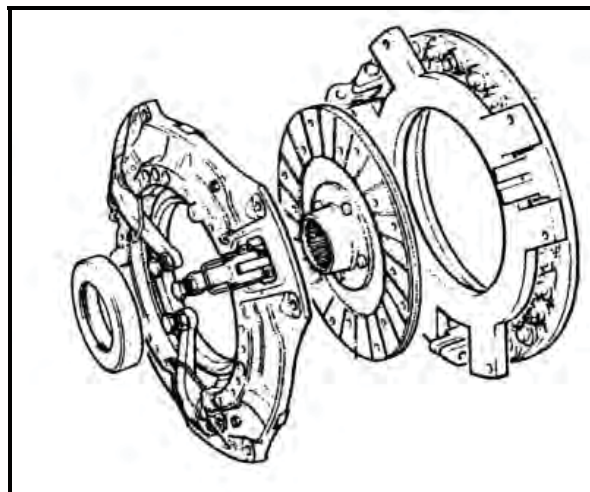

- 5.8.1 Name the THREE main components of the above clutch. (3)
- 5.8.2 Give THREE reasons for equipping a tractor with a clutch. (3)
- 5.9 Purchasing a second-hand tractor requires the buyer to have sufficient time for inspection. Name the parts that should receive special attention when examining a second-hand tractor. (3)

[40]



QUESTION 6: WATER MANAGEMENT**Start this question on a NEW page.**

- 6.1 Centre-pivot irrigation is a very effective watering system in cases where farm labour is scarce.
- 6.1.1 Give reasons why centre-pivot irrigation is a labour-saving system. (3)
- 6.1.2 Explain the design principles of the centre-pivot irrigation system that assures effective watering of the whole area. (4)
- 6.2 Give THREE reasons for using irrigation software in the management of irrigation systems. (3)
- 6.3 A family living on a farm uses water from a nearby river for their household needs.

Study the sketch below and answer the questions that follow.

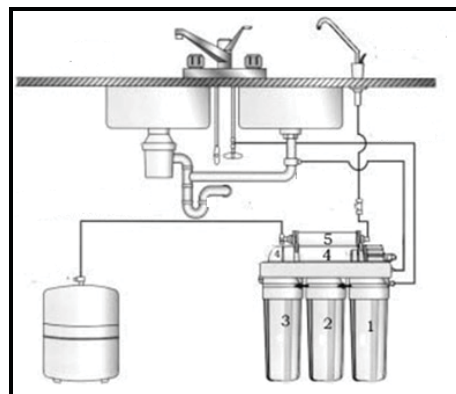

- 6.3.1 Give TWO reasons for installing such a system in the farm house. (2)
- 6.3.2 List THREE other effective methods that can be used to purify drinking water. (3)
- 6.4 Briefly describe the problems associated with irrigation of agricultural land in South Africa. (3)
- 6.5 Name FOUR different types of home drainage systems. (4)
- 6.6 Certain substances must never enter a septic tank system because it may have a negative influence on the bacteria in the septic tank and may prevent the septic tank from functioning properly.
- Name THREE such harmful substances. (3)



6.7 Precision farming is a combination of several technologies and originated in the United States of America.

6.7.1 Name THREE advantages of variable-rate technology (VRT) for farmers. (3)

6.7.2 The illustration below indicates an application of information technology.

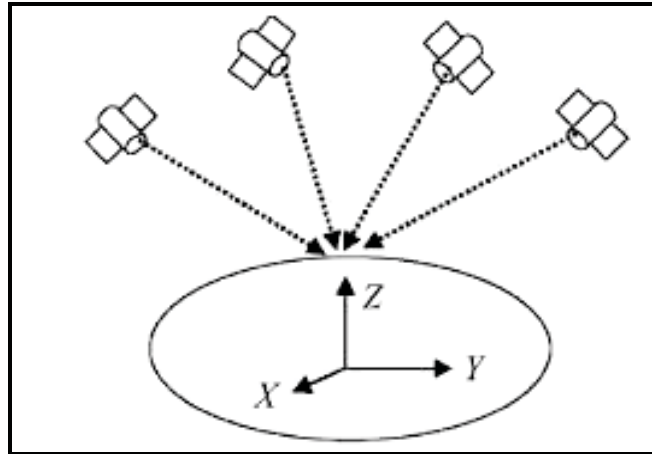

Name TWO other advanced technology systems, except VRT, that are used for precision farming. (2)

[30]

TOTAL SECTION B: 160
GRAND TOTAL: 200