



# basic education

---

Department:  
Basic Education  
**REPUBLIC OF SOUTH AFRICA**

## SENIOR CERTIFICATE EXAMINATION

**LIFE SCIENCES P1**

**2015**

**MARKS: 150**

**TIME: 2½ hours**

**This question paper consists of 15 pages.**

**INSTRUCTIONS AND INFORMATION**

Read the following instructions carefully before answering the questions.

1. Answer ALL the questions.
2. Write ALL the answers in the ANSWER BOOK.
3. Start the answers to EACH question at the top of a NEW page.
4. Number the answers correctly according to the numbering system used in this question paper.
5. Present your answers according to the instructions of each question.
6. ALL drawings must be done in pencil and labelled in blue or black ink.
7. Draw diagrams, flow charts or tables only when asked to do so.
8. The diagrams in this question paper are NOT necessarily drawn to scale.
9. Do NOT use graph paper.
10. You must use a non-programmable calculator, protractor and a compass, where necessary.
11. Write neatly and legibly.

**SECTION A****QUESTION 1**

- 1.1 Various options are given as possible answers to the following questions. Choose the answer and write only the letter (A to D) next to the question number (1.1.1 to 1.1.10) in the ANSWER BOOK, for example 1.1.11 D.
- 1.1.1 Which ONE of the following factors will decrease food security?
- A Planting more fruit trees
  - B Increase in biodiversity
  - C Increase in alien plants
  - D Controlled use of fertilisers
- 1.1.2 Which gas released from landfill sites can be used for domestic purposes?
- A Carbon dioxide
  - B Oxygen
  - C Carbon monoxide
  - D Methane
- 1.1.3 The auditory nerve transmits impulses to the ...
- A cerebrum and medulla oblongata.
  - B cerebrum and cerebellum.
  - C cerebellum and medulla oblongata.
  - D cerebrum and corpus callosum.
- 1.1.4 Which ONE of the following is a characteristic of external fertilisation?
- A Copulation takes place.
  - B A large number of eggs are produced.
  - C The embryo is protected in the female body.
  - D Sperm is introduced into the body of the female.
- 1.1.5 During a 400 metre race, the autonomic nervous system of an athlete will decrease the ...
- A heartbeat.
  - B flow of blood to the intestine.
  - C flow of blood to the muscles.
  - D breathing rate.

QUESTIONS 1.1.6 and 1.1.7 refer to the diagrams below which illustrate different phases of meiosis.

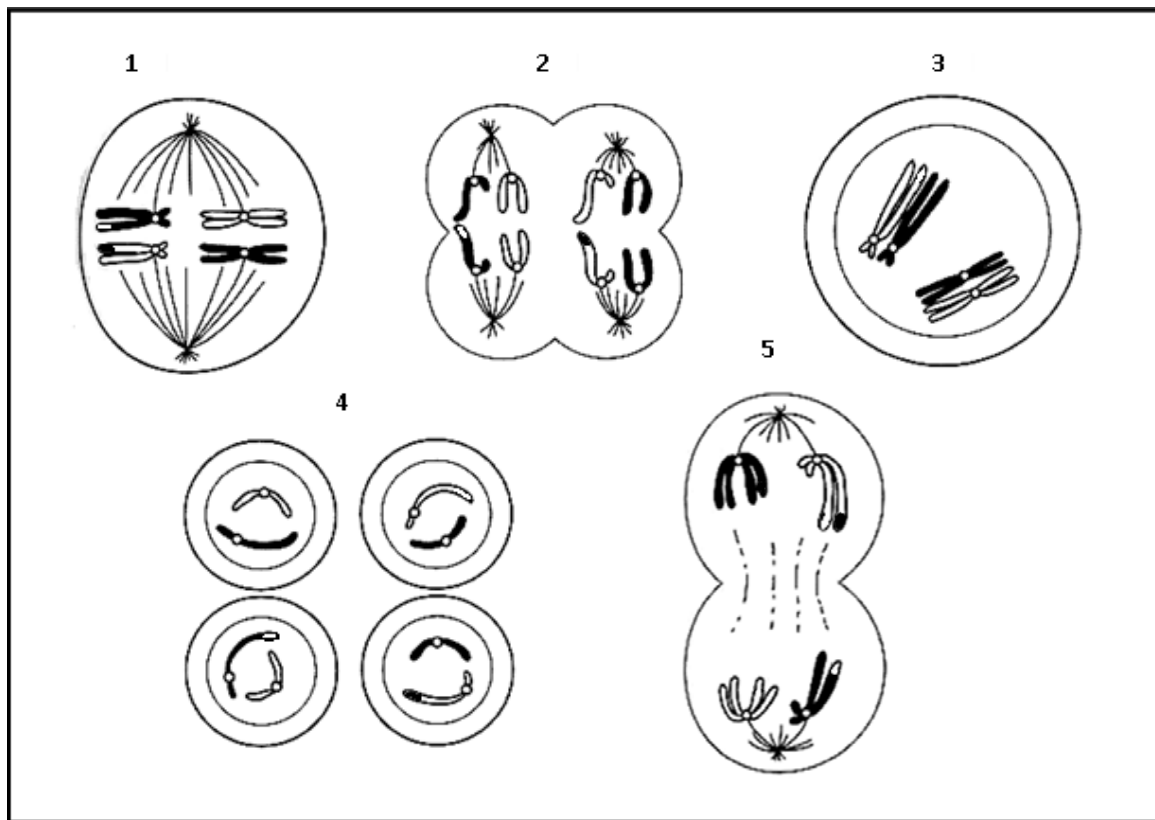

1.1.6 The correct sequence of the diagrams above is ...

- A 1, 2, 3, 4, 5.
- B 3, 5, 1, 4, 2.
- C 1, 3, 4, 2, 5.
- D 3, 1, 5, 2, 4.

1.1.7 In which ONE of the phases above does random arrangement of chromosomes at the equator take place?

- A 3
- B 1
- C 5
- D 4

1.1.8 An extract from a gland of an adult monkey was injected into the bloodstream of a young monkey. It caused the young monkey to grow abnormally tall. From which gland was the extract obtained?

- A Hypothalamus
- B Adrenal gland
- C Hypophysis/Pituitary gland
- D Pancreas

1.1.9 When a person is being chased by a fierce dog, ...

- A insulin and glucagon levels will decrease.
- B adrenalin and thyroxin levels will increase.
- C FSH and thyroxin levels will increase.
- D adrenalin and insulin levels will decrease.

1.1.10 Which ONE of the following would be the result of a person drinking a large volume of water?

	AMOUNT OF ADH SECRETED	REABSORPTION OF WATER FROM KIDNEY TUBULE	VOLUME OF URINE PRODUCED
A	Decreases	Decreases	Increases
B	Decreases	Increases	Decreases
C	Increases	Decreases	Increases
D	Increases	Increases	Decreases

(10 x 2) (20)

1.2 Give the correct **biological term** for each of the following descriptions. Write only the term next to the question number (1.2.1 to 1.2.9) in the ANSWER BOOK.

- 1.2.1 The variety of plant and animal species on Earth
- 1.2.2 The membrane that transmits sound vibrations to the inner ear
- 1.2.3 The reproductive strategy where the development of the young takes place in the uterus of the mother
- 1.2.4 The male reproductive tube that connects the testis with the urethra
- 1.2.5 The reproductive strategy involving the laying of eggs
- 1.2.6 Splitting of the cytoplasm during cell division
- 1.2.7 The access, by all people at all times, to adequate, safe and nutritious food
- 1.2.8 The part of the ear that equalises the pressure on either side of the tympanic membrane
- 1.2.9 A defective condition of the eye where a person can see nearby objects clearly while distant objects are blurred (9 x 1) (9)

- 1.3 Indicate whether each of the descriptions in COLUMN I applies to **A ONLY**, **B ONLY**, **BOTH A AND B** or **NONE** of the items in COLUMN II. Write **A only**, **B only**, **both A and B** or **none** next to the question number (1.3.1 to 1.3.4) in the ANSWER BOOK.

COLUMN I	COLUMN II
1.3.1 Stimulated by changes in the position of the head	A: Maculae B: Cristae
1.3.2 Occurs during accommodation for distant vision	A: Suspensory ligaments slacken B: Lens becomes less convex
1.3.3 Occurs in the iris under dim light conditions	A: Circular muscles relax B: Radial muscles contract
1.3.4 A young bird is helpless soon after hatching	A: Precocial development B: Altricial development

(4 x 2)

(8)

- 1.4 Study the diagram of a longitudinal section through a human eye below.

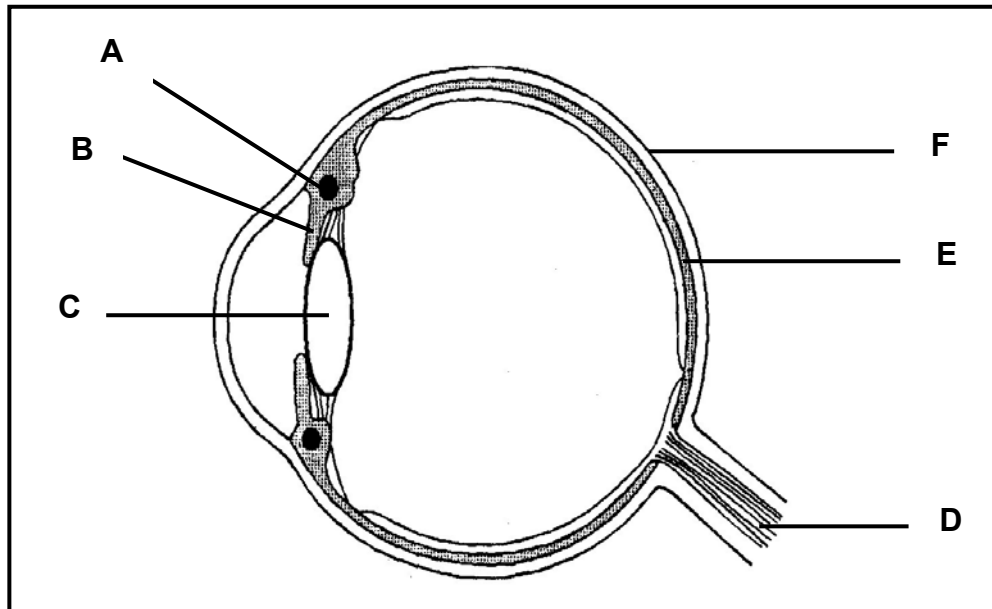

- 1.4.1 Label parts **A**, **B** and **E**. (3)
- 1.4.2 Give the LETTER only of the part which:
- (a) Protects the delicate internal structures (1)
  - (b) Transmits impulses to the cerebrum (1)
  - (c) Becomes cloudy or opaque as a person gets older, leading to decreased vision (1)
  - (d) Contracts or relaxes when the distance of an object from the eye changes (1)

(7)

1.5 Study the diagram below showing a phase of meiosis.

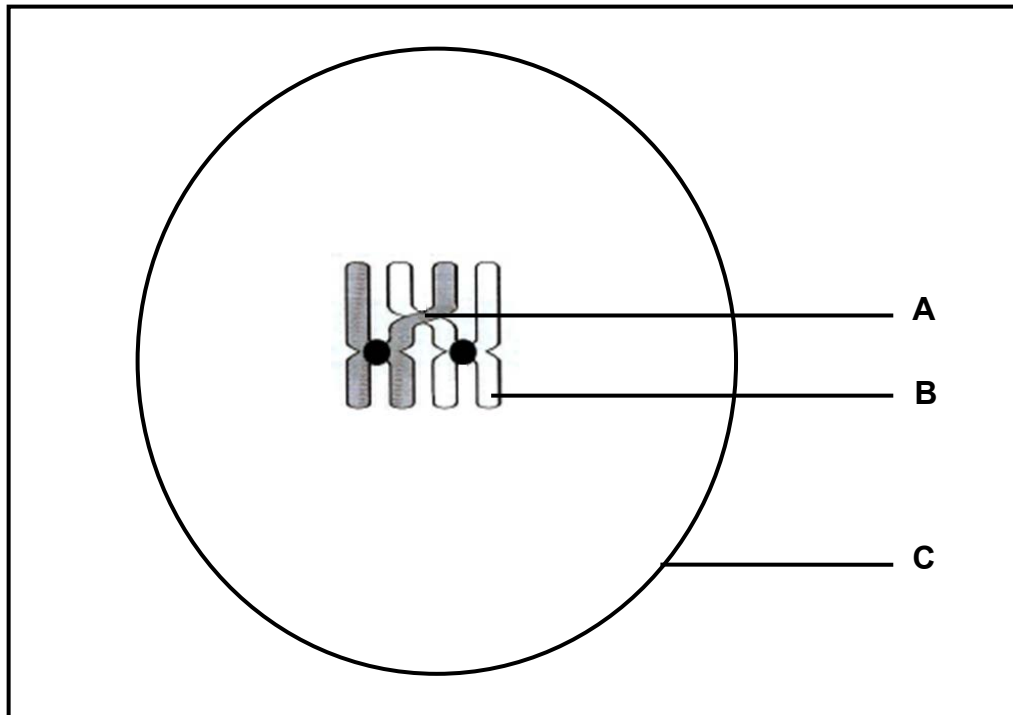

1.5.1 Identify:

- (a) Region **A** (1)
- (b) Part **B** (1)
- (c) Part **C** (1)
- (d) Phase of meiosis (1)
- (e) Process taking place in this phase of meiosis (1)

1.5.2 Predict what would happen if the process identified in QUESTION 1.5.1(e) above did NOT occur. (1)  
(6)

**TOTAL SECTION A: 50**

**SECTION B****QUESTION 2**

- 2.1 Study the diagram below of a section through a human spinal cord and the neurons involved in a reflex arc.

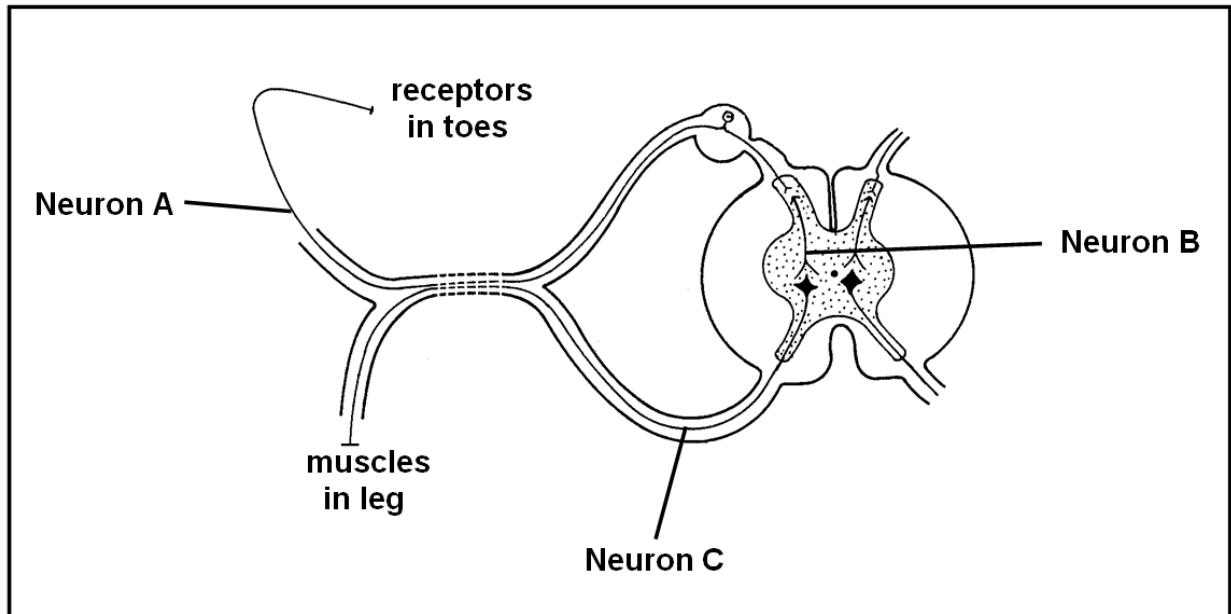

- 2.1.1 Define a *reflex action*. (2)
- 2.1.2 Identify neurons **A**, **B** and **C**. (3)
- 2.1.3 Write down only the LETTER of the neuron (**A** or **C**) which is probably damaged if a person:
- (a) Can feel the stimulus but cannot respond (1)
- (b) Is able to walk but cannot detect any stimulus (1)
- 2.1.4 State the significance of the reflex action in humans. (1)
- (8)**



2.2 Read the passage below and answer the questions that follow.

### EXERCISE AND SPERM COUNT

Research was conducted to determine the effect of lifestyle on the sperm count of young males. In this study, 189 young male students from a university in New York filled out questionnaires on their physical activity, diet, stress and other lifestyle factors. Each male student then provided a semen sample.

The results showed that the male students who exercised for more than 15 hours a week had a sperm count 73 percent higher than those who exercised fewer than 5 hours a week.

A second investigation showed that men who watched more than 20 hours of TV per week instead of exercising had a 44 percent lower sperm count than men who watched little or no TV.

A person who exercises, secretes more antioxidant enzymes that can prevent a natural process called oxidative stress from damaging cell membranes in the body. This damage can disrupt the formation of new sperm. When watching TV or sitting, the scrotum gets pushed against their body, making the region of the testis hotter and possibly preventing new sperm from being produced.

[Adapted from *National Geographic News*, February 2013]

- 2.2.1 Name the specific meiotic process responsible for the production of sperm cells. (1)
- 2.2.2 Explain why a high temperature in the region of the testis may prevent the production of new sperm. (2)
- 2.2.3 State a general conclusion that can be drawn from the results in the first investigation. (2)
- 2.2.4 State ONE way in which the reliability of this study can be increased. (1)
- 2.2.5 Draw a labelled diagram to show the structure of a sperm cell. (4)
- (10)**

- 2.3 Studies have shown that when the blood alcohol content exceeds 0,1 mg/100 ml, a person displays a slowing of motor coordination, as well as poor judgement and hearing.

An investigation was done to determine the influence of blood alcohol content on reaction time. The reaction time was tested by measuring the braking response time of a motorcyclist.

The results are shown in the table below.

<b>BLOOD ALCOHOL CONTENT (mg/100 ml)</b>	<b>BRAKING RESPONSE TIME (s)</b>
0	0,572
0,15	0,585
0,25	0,610

[Adapted from [www-nrd.nhtsa.dot.gov](http://www-nrd.nhtsa.dot.gov)]

- 2.3.1 Calculate how much longer (in seconds) the braking response time of the motorcyclist was when there was 0,25 mg/100 ml of alcohol in his blood compared to when there was no alcohol in the blood. (2)
- 2.3.2 Describe the general relationship between the blood alcohol content and the braking response time. (2)
- 2.3.3 Explain why poor judgement of a motorist can lead to an accident. (2)
- 2.3.4 Identify the part of the brain affected by alcohol that leads to the following:
- (a) Hearing being affected (1)
  - (b) Loss of judgement (1)
  - (c) Motor coordination being affected (1)
- 2.3.5 Explain the purpose of measuring the braking response of the motorcyclist when the blood alcohol content was 0 mg/100 ml. (2)
- (11)**

2.4 Lerato conducted an investigation to determine the effect of exercise on skin temperature.

She asked 100 learners in her school to participate in the investigation. The sample consisted of 100 girls of the same age.

The investigation was done as follows:

- The learners were divided into two groups of 50 each (Groups **A** and **B**).
- The skin temperature was measured for all the participants.
- Group **A** was asked to run around the sportsfield for 10 minutes.
- Group **B** was asked to remain seated on the benches next to the field for 10 minutes.

After 10 minutes the skin temperature of all participants was measured and the average was calculated for each group (**A** and **B**).

2.4.1 In this investigation, identify the:

(a) Independent variable (1)

(b) Dependent variable (1)

2.4.2 State TWO steps that Lerato took into consideration during the planning stage of the investigation. (2)

2.4.3 What is the expected results for the participants in group **A**? (1)

2.4.4 State ONE factor that Lerato kept constant during the investigation. (1)

2.4.5 Which of the two groups (**A** or **B**) will release more sweat? (1)

2.4.6 Explain why sweat production will increase in the group identified in QUESTION 2.4.5. (4)  
**(11)**  
**[40]**

**QUESTION 3**

- 3.1 The table below shows the concentration of abscisic acid and gibberellins in germinating seeds over 10 days.

TIME (DAYS)	HORMONE CONCENTRATION IN GERMINATING SEEDS (ARBITRARY UNITS)	
	ABSCISIC ACID	GIBBERELLINS
0	20	0
2	8	1
4	4	4
6	3	7
8	2	10
10	1	12

[Adapted from *Biology Cambridge*, 2013]

- 3.1.1 Draw a line graph to show the changes in the concentration of abscisic acid over the period of the investigation. (6)
- 3.1.2 State what happened to the concentration of each of the following hormones over the period of the investigation:
- (a) Abscisic acid (1)
  - (b) Gibberellins (1)
- (8)
- 3.2 Explain the growth response of a plant when the stem is exposed to light coming from one side only. (4)

- 3.3 Study the flow diagram below showing the response of an endocrine gland to changes in the amount of glucose found in the blood.

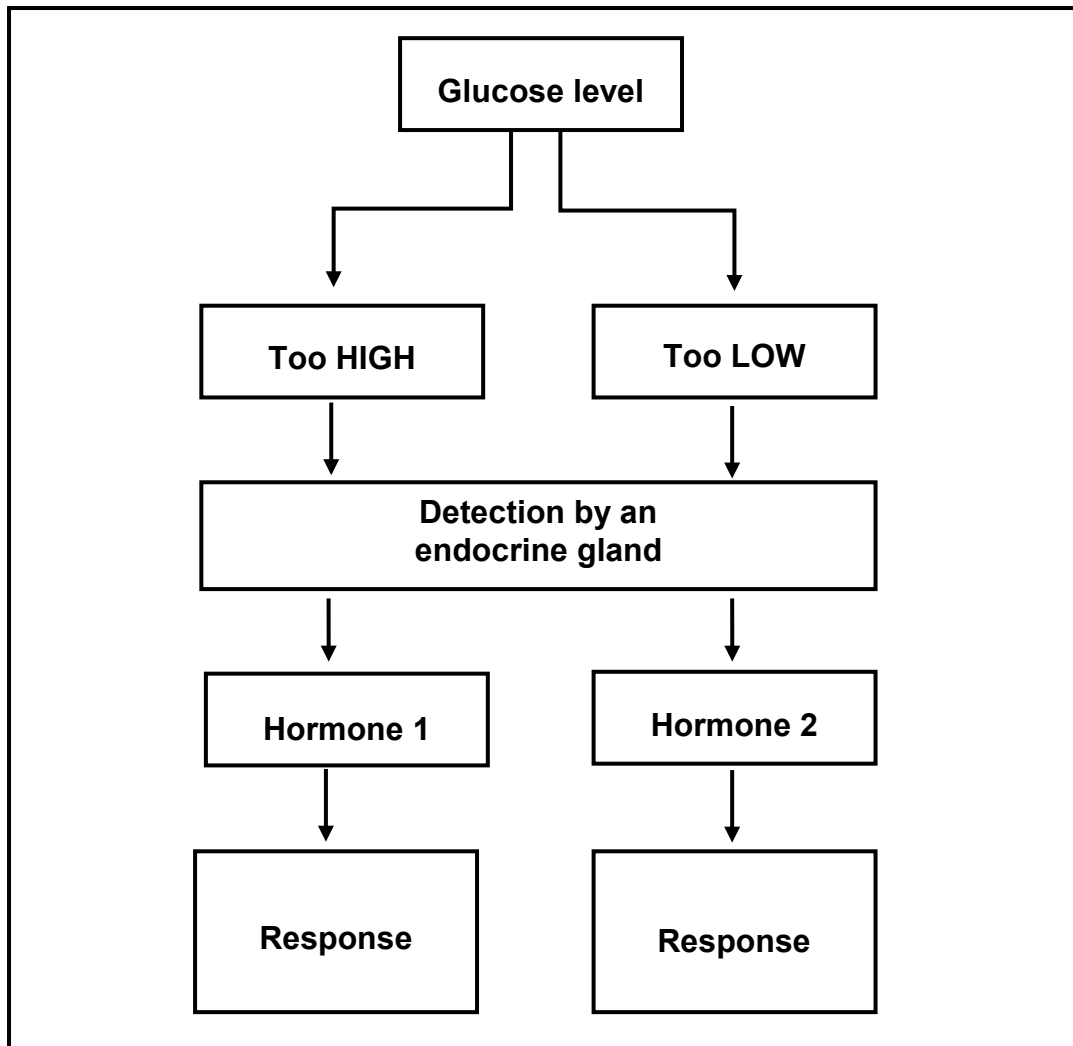

- 3.3.1 Define the term *endocrine gland*. (2)
- 3.3.2 Identify:
- (a) Hormone 1 (1)
- (b) Hormone 2 (1)
- 3.3.3 Name the gland that releases hormone 1 and hormone 2. (1)
- 3.3.4 Explain the consequences for a person if the gland mentioned in QUESTION 3.3.3 fails to release hormone 1. (4)
- (9)

- 3.4 Energy in South Africa is mainly generated from coal power stations. The pie chart below shows the energy consumption in different sectors of a South African city in 2007.

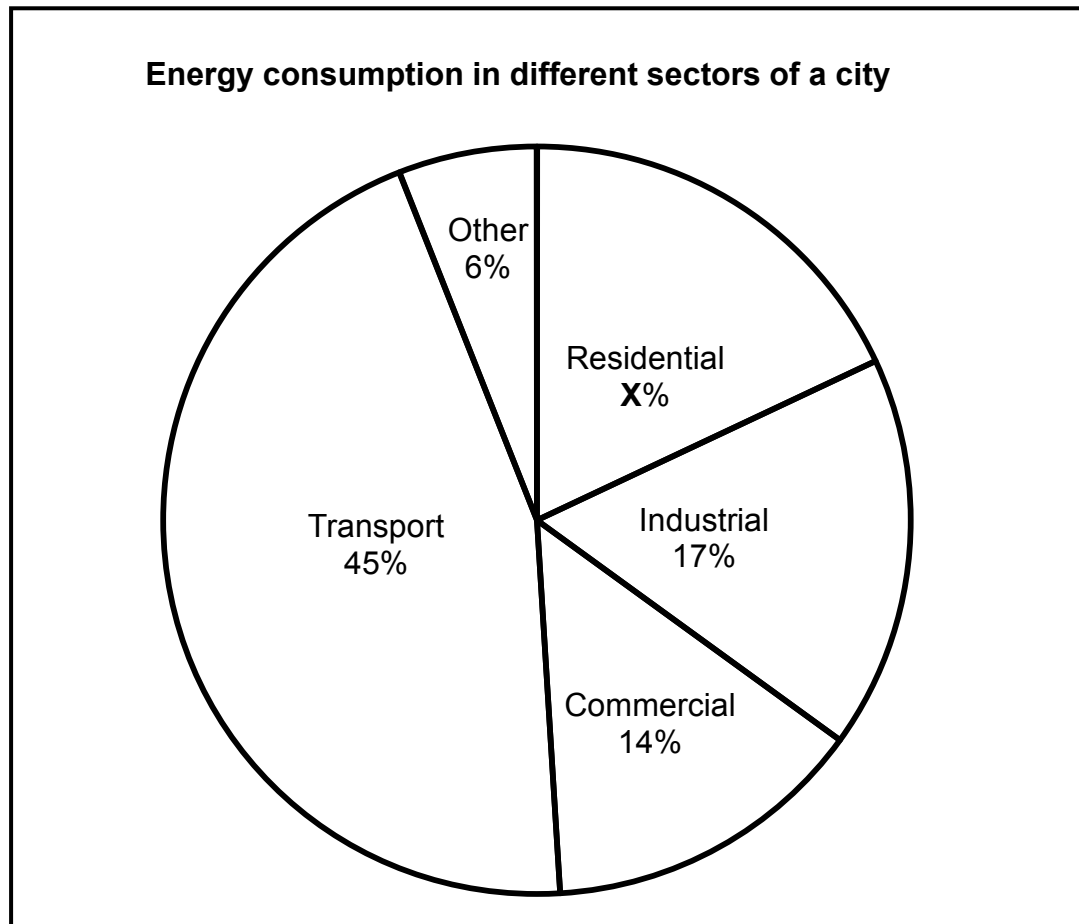

[Adapted from *Energy Scenarios for CT to – 2050, 2011*]

- 3.4.1 Determine the value of **X**. Show ALL calculations. (2)
- 3.4.2 Which sector consumes the most energy in this city? (1)
- 3.4.3 The residential energy consumption in this city increased by 3% in 2009. Give TWO possible reasons for this increase. (2)
- 3.4.4 Explain the impact of the increased use of energy generated from coal power stations on climate change. (4)
- 3.4.5 South Africa, like many other countries, has signed a declaration to reduce its CO<sub>2</sub> output over time.
- Explain TWO strategies that could be implemented by the South African government to achieve this reduction in CO<sub>2</sub> output. (4)

**(13)**

3.5 Water hyacinth is an invasive alien species. It grows and floats in dams and lakes. It is a fast-growing species which can invade, cover and take over the whole dam or lake.

3.5.1 What is meant by *invasive alien species*? (2)

3.5.2 Explain TWO ways in which alien plants, like the water hyacinth, could upset the balance in ecosystems. (4)  
(6)  
[40]

**TOTAL SECTION B: 80**

## SECTION C

### QUESTION 4

Describe the interaction and the influence of hormones on the events during the menstrual cycle.

Content: (17)  
Synthesis: (3)

**NOTE:** NO marks will be awarded for answers in the form of flow charts, tables or diagrams.

**TOTAL SECTION C: 20**  
**GRAND TOTAL: 150**