

STAPLE



# basic education

Department:  
Basic Education  
REPUBLIC OF SOUTH AFRICA

**NATIONAL  
SENIOR CERTIFICATE**

**GRADE 12**

**ENGINEERING GRAPHICS AND DESIGN P2**  
**FEBRUARY/MARCH 2017**

**MARKS: 100**

**TIME: 3 hours**

**This question paper consists of 6 pages.**

## INSTRUCTIONS AND INFORMATION

1. This question paper consists of FOUR questions.
2. Answer ALL the questions.
3. ALL orthographic drawings are in third-angle projection, unless otherwise stated.
4. ALL drawings must be completed using instruments, unless otherwise stated.
5. ALL answers must be drawn accurately and neatly.
6. ALL the questions must be answered on the QUESTION PAPER as instructed.
7. ALL the pages, irrespective of whether the question was attempted or not, must be re-stapled in numerical sequence in the TOP LEFT-HAND CORNER ONLY.
8. Proper planning is essential in order to complete all the questions.
9. Print your examination number in the block provided on every page.
10. Any details or dimensions not given must be assumed in good proportion.

FOR OFFICIAL USE ONLY															
QUESTION	MARKS OBTAINED			$\frac{1}{2}$	SIGN	MODERATED			$\frac{1}{2}$	SIGN	RE-MARKING			$\frac{1}{2}$	SIGN
1															
2															
3															
4															
TOTAL															
	2	0	0			2	0	0			2	0	0		

FINAL CONVERTED MARK	CHECKED BY
100	

<b>COMPLETE THE FOLLOWING:</b>
CENTRE NUMBER
CENTRE NUMBER
EXAMINATION NUMBER
EXAMINATION NUMBER

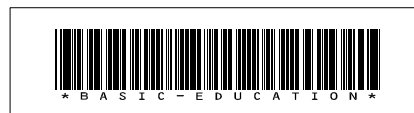

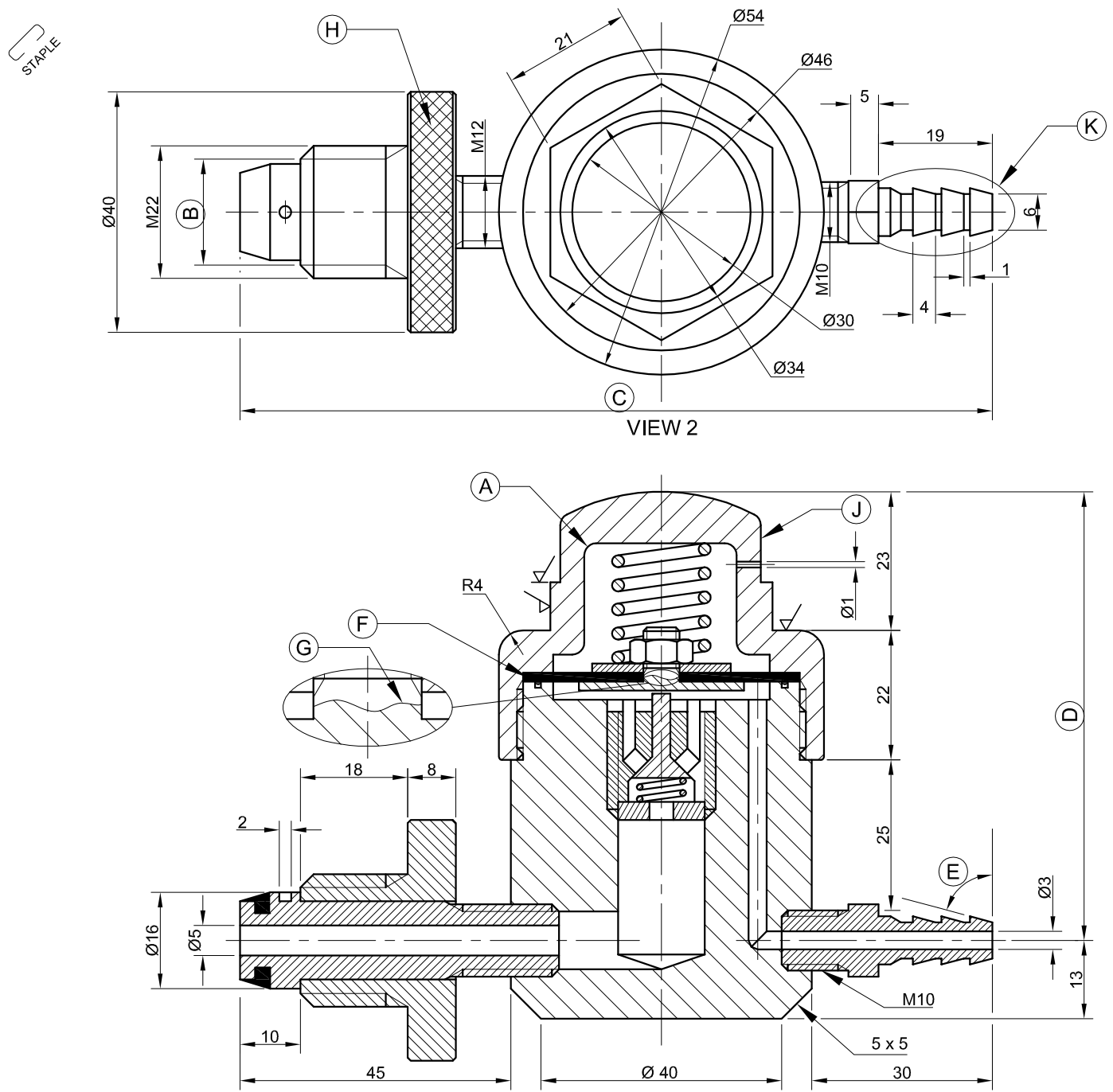

PARTS LIST		
PART	QUANTITY	MATERIAL
1	1	BRASS
2	1	BRASS
3	1	RUBBER
4	1	BRASS
5	1	BRASS
6	1	SPRING STEEL
7	1	STAINLESS STEEL
8	1	RUBBER
9	1	SPRING STEEL
10	1	BRASS
11	1	BRASS

APPROVED: SOON      DATE: 2015-12-06  
 CHECKED: VERNON      DATE: 2015-11-10  
 DRAWN: WIKUS      DATE: 2015-10-31  
 DRAWING PROGRAMME: AUTOCAD 2016  
 ALL UNSPECIFIED RADII ARE R2.      SCALE 1 : 1  
 METHOD OF MACHINING: MILLING

**THE ONE GAS COMPANY**      75 AIR STREET  
 www.theonegas.co.za  
 012 357 8910

TITLE  
**GAS REGULATOR**

**QUESTION 1: ANALYTICAL (MECHANICAL)**

**Given:**  
 An assembly drawing showing two views of a gas regulator assembly, a parts list, a title block and a table of questions. The drawings have not been prepared to the indicated scale.

**Instructions:**  
 Complete the table below by neatly answering the questions, which refer to the accompanying drawing and the title block. [30]

QUESTIONS		ANSWERS	
1	What is the title of the drawing?	1	
2	What is the web address of the company?	1	
3	What method of machining is prescribed?	1	
4	Which drawing program was used to prepare the drawing?	1	
5	On what date was the drawing drawn?	1	
6	Who approved the drawing?	1	
7	What material is used to manufacture the seal?	1	
8	What is VIEW 1 called?	1	
9	Name the feature at A.	1	
10	Determine the complete dimensions at B: C: D:	3	
11	Measure the angle at E.	1	
12	Why is the part at F filled in solid?	1	
13	What is indicated by the feature at G?	1	
14	Name the type of finish at H.	1	
15	Refer to the parts list and identify the part at J.	1	
16	How many surfaces of the gas regulator assembly must be machined?	1	
17	Why is the feature at K tapered to one side only?	2	
18	Insert the cutting plane on VIEW 2 and label it S-S.	3	
19	In the space below (ANSWER 19), draw, in neat freehand, the convention for a coil spring.	3	
20	In the space below (ANSWER 20), draw, in neat freehand, the symbol for the projection system used.	4	
<b>TOTAL</b>		<b>30</b>	

ANSWER 19:  
 Convention for a coil spring

ANSWER 20:  
 Projection symbol

EXAMINATION NUMBER

EXAMINATION NUMBER **2**





**QUESTION 2: LOCI**

**NOTE:** Answer QUESTIONS 2.1 and 2.2.

**2.1 LOCI (HELIX)**

**Given:**

- A front view and left view of the shaft of an auger with Q indicating the starting position
- The position of point P on the drawing sheet

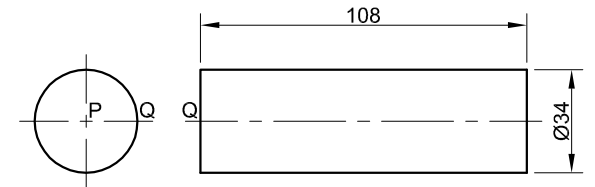

AUGER SHAFT DETAIL

**Specifications:**

- Nominal diameter : Ø74 mm
- Pitch : 72 mm
- Turns : ONE AND A HALF
- Direction : Left-handed

**Instructions:**

Draw, to scale 1 : 1, the complete front view and left view of the auger.

- Show ALL construction.
- NO hidden detail is required.

[23]

**ASSESSMENT CRITERIA 2.1**

1	GIVEN + CENTRE LINES	3		
2	CONSTRUCTION	8		
3	OUTER HELIX	5 1/2		
4	INNER HELIX + SHAFT	4 1/2		
5	CURVE QUALITY	2		
PENALTIES (-)				
<b>SUBTOTAL</b>		<b>23</b>		

P

**2.2 CAM**

**Given:**

The bottom left 0° starting position of the displacement graph on the answer sheet

**Motion:**

- The follower rises with uniform motion for 15 mm over the first 30° of rotation.
- There is a dwell period for the next 15°.
- The follower rises with simple harmonic motion for 65 mm over the next 135°, to the maximum displacement of 80 mm.
- There is a dwell period for the next 90°.
- The follower returns with uniform acceleration and retardation to the original position over the rest of the rotation.

**Instructions:**

Draw, to a displacement scale of 1 : 1 and a horizontal scale of 360° = 180 mm, the complete displacement graph for the required motion.

- Label the graph and indicate the horizontal scale.
- Show ALL construction.

[16]

0°

**ASSESSMENT CRITERIA 2.2**

1	CONSTRUCTION	6		
2	POINTS + CURVES	9		
3	LABELS	1		
PENALTIES (-)				
<b>2.2 SUBTOTAL</b>		<b>16</b>		
<b>2.1 SUBTOTAL</b>		<b>23</b>		
<b>TOTAL</b>		<b>39</b>		

EXAMINATION NUMBER

EXAMINATION NUMBER

3





**QUESTION 3: ISOMETRIC DRAWING**

**Given:**

- The front view and top view of a bracket
- The position of point S on the drawing sheet

**Instructions:**

Using scale 1 : 1, convert the orthographic views of the bracket to an isometric drawing.

- Make S the lowest point of the drawing.
- Show ALL construction.
- NO hidden detail is required.

**[39]**

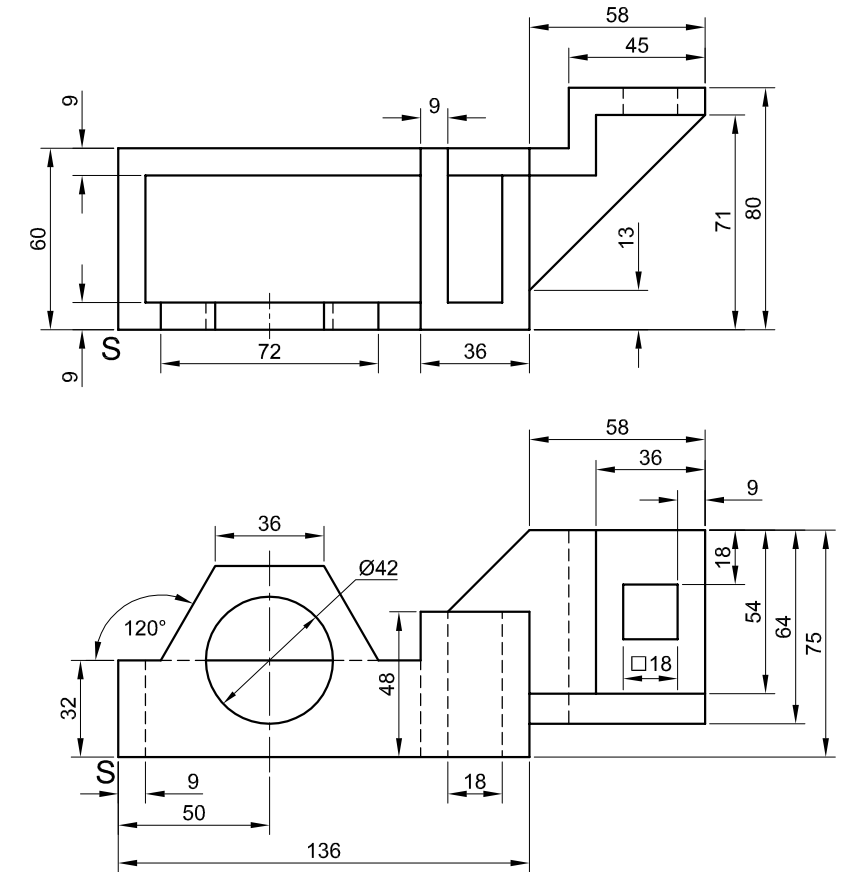

S

ASSESSMENT CRITERIA			
1	AUXILIARY VIEW + PLACEMENT	2	
2	FRONT + REAR SECTION	25	
3	HEXAGON	4	
4	CIRCLE + CL	8	
PENALTIES (-)			
<b>TOTAL</b>		<b>39</b>	
EXAMINATION NUMBER			
EXAMINATION NUMBER			4



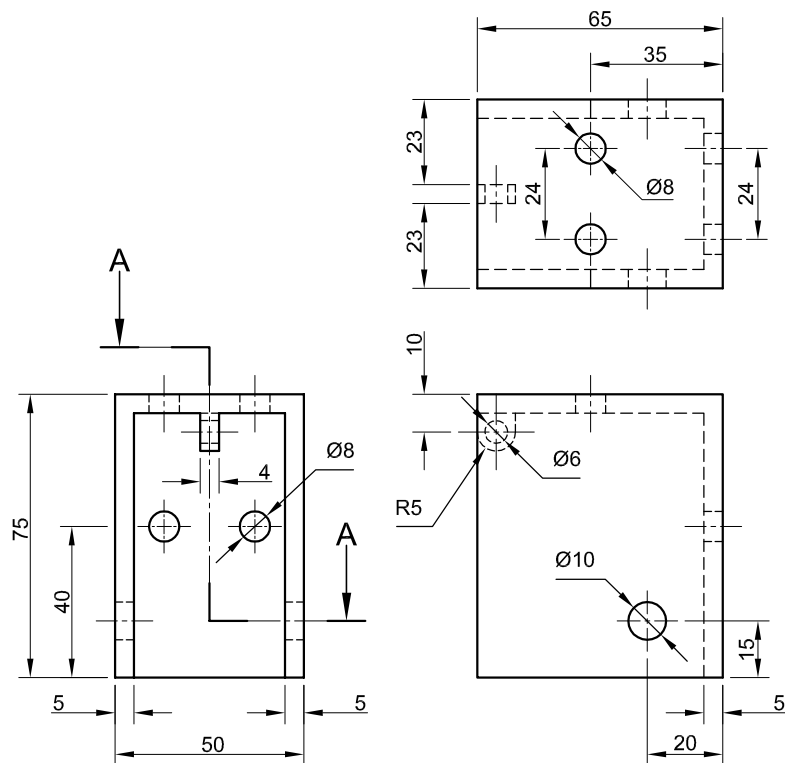

HOUSING [1]

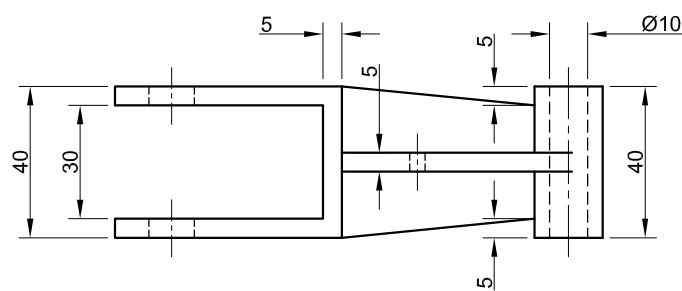

FORK [2]

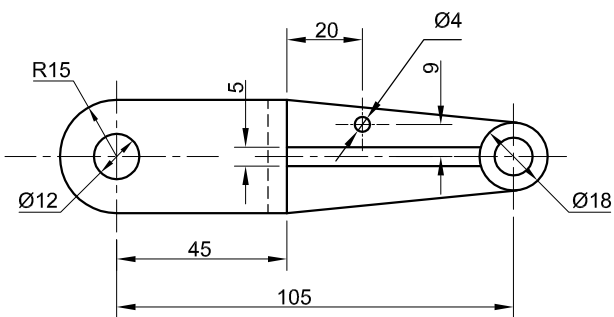

PIN [3]

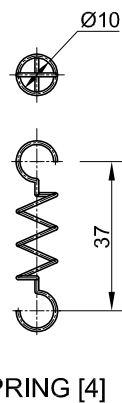

SPRING [4]

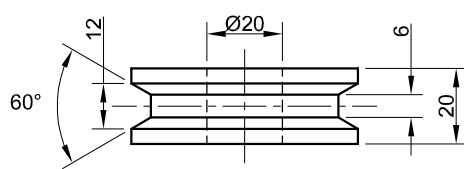

PULLEY [7]

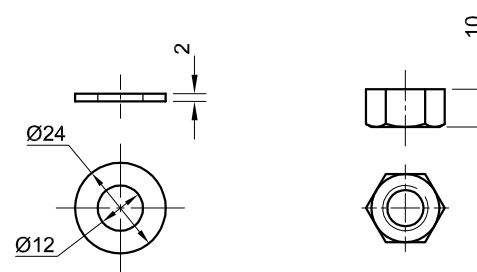

WASHER [8]

M12 NUT [9]

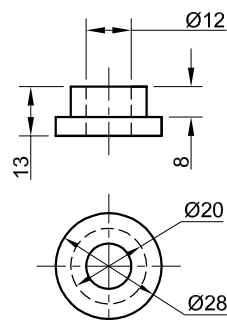

BUSH [6]

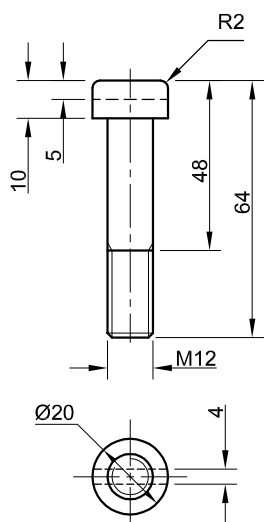

M12 BOLT [5]

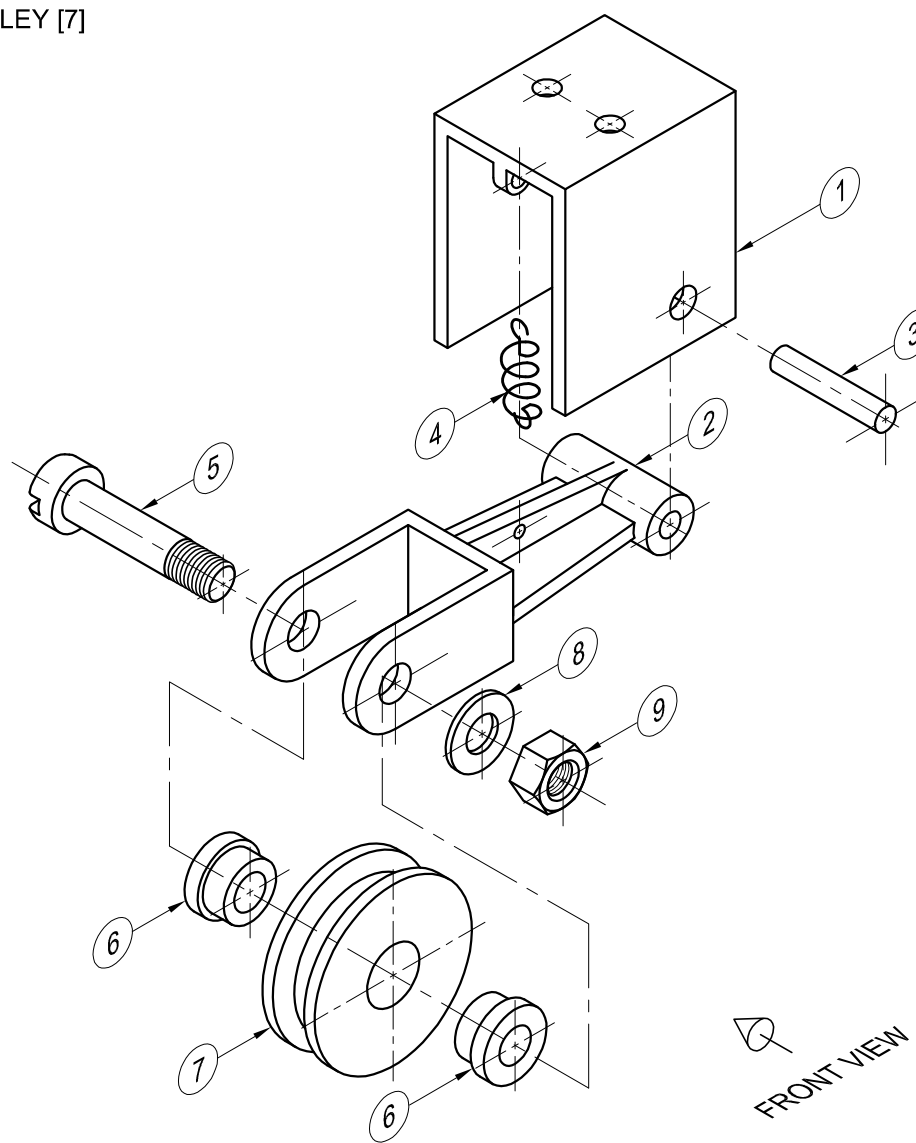

EXPLODED ISOMETRIC DRAWING

FRONT VIEW

**QUESTION 4: MECHANICAL ASSEMBLY**

**Given:**

- Orthographic views of each of the parts of a tension pulley assembly
- The exploded isometric drawing of the parts of the tension pulley assembly, showing the position of each part relative to all the others

**Instructions:**

- Answer this question on page 6.
- Draw, to scale 1 : 1 and in third-angle orthographic projection, the following views of the assembled parts of the tension pulley assembly:
  - 4.1 The front view as seen from the direction of the arrow shown on the exploded isometric drawing
  - 4.2 A half-sectional top view on cutting plane A-A. Show the front half in section, in accordance with the cutting plane that is shown on the left view of the housing (part 1).
  - 4.3 The left view

**NOTE:**

- Planning is essential.
- ALL drawings must comply with the guidelines contained in the SANS 10111.
- The convention of symmetry may not be applied.
- The spring (part 4) must be drawn in convention and in neat freehand.
- Show THREE faces of the M12 nut in the top view.
- Add cutting plane A-A.
- NO hidden detail is required.

[92]

PARTS LIST			
PART	QUANTITY	MATERIAL	
1	HOUSING	1	MILD STEEL
2	FORK	1	CAST IRON
3	PIN	1	MILD STEEL
4	SPRING	1	SPRING STEEL
5	M12 BOLT	1	MILD STEEL
6	BUSH	2	BRASS
7	PULLEY	1	CAST IRON
8	WASHER	1	MILD STEEL
9	M12 NUT	1	MILD STEEL

TITLE **TENSION PULLEY**

**GENERAL**  
ENGINEERING WORKS

54 PEARL ROAD  
PERSEVERANCE  
6000  
041 335 1600

ALL DIMENSIONS ARE IN MILLIMETRES. ALL UNSPECIFIED RADII ARE R5.

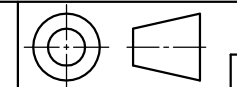



FOR OFFICIAL USE ONLY	
INCORRECT ORTHOGRAPHIC PROJECTION	
INCORRECT SCALE	
INCORRECT HATCHING	
PARTS NOT ASSEMBLED	
TOTAL PENALTIES (-)	

ASSESSMENT CRITERIA			
FRONT VIEW			
1	HOUSING + PIN	3	
2	FORK	4	
3	PULLEY	1	
4	M12 BOLT + WASHER + M12 NUT	6	
<b>SUBTOTAL</b>		<b>14</b>	
SECTIONAL TOP VIEW			
1	HOUSING + PIN	7	
2	FORK	10 $\frac{1}{2}$	
3	M12 BOLT	7	
4	BUSH	4	
5	PULLEY	7 $\frac{1}{2}$	
6	WASHER + M12 NUT	4 $\frac{1}{2}$	
<b>SUBTOTAL</b>		<b>40 <math>\frac{1}{2}</math></b>	
LEFT VIEW			
1	HOUSING	4 $\frac{1}{2}$	
2	FORK	1 $\frac{1}{2}$	
3	SPRING	2	
4	BUSH	1	
5	PULLEY	4 $\frac{1}{2}$	
6	M12 BOLT + WASHER + M12 NUT	8 $\frac{1}{2}$	
<b>SUBTOTAL</b>		<b>22</b>	
GENERAL			
1	CENTRE LINES	6 $\frac{1}{2}$	
2	ASSEMBLY	9	
<b>SUBTOTAL</b>		<b>15 <math>\frac{1}{2}</math></b>	
<b>TOTAL</b>		<b>92</b>	
PENALTIES (-)			
<b>GRAND TOTAL</b>			
EXAMINATION NUMBER			
EXAMINATION NUMBER			6

