



basic education

Department:
Basic Education
REPUBLIC OF SOUTH AFRICA

NATIONAL SENIOR CERTIFICATE

GRADE 12

AGRICULTURAL TECHNOLOGY

FEBRUARY/MARCH 2016

MARKS: 200

TIME: 3 hours

This question paper consists of 16 pages.

INSTRUCTIONS AND INFORMATION

1. GENERAL INSTRUCTIONS AND INFORMATION
 - 1.1 This question paper consists of TWO sections, namely SECTION A and SECTION B.
 - 1.2 BOTH sections are COMPULSORY.
 - 1.3 Answer ALL the questions in the ANSWER BOOK.
 - 1.4 Number the answers correctly according to the numbering system used in this question paper.
 - 1.5 You may use a non-programmable calculator.
 - 1.6 Write neatly and legibly.
2. SECTION A: SHORT QUESTIONS
 - 2.1 This section consists of THREE questions.
 - 2.2 Follow the instructions when answering the questions.
3. SECTION B: STRUCTURED LONG QUESTIONS
 - 3.1 This section consists of FIVE questions.
 - 3.2 Start EACH question on a NEW page.

SECTION A**QUESTION 1**

- 1.1 Various options are provided as possible answers to the following questions. Choose the answer and write only the letter (A–D) next to the question number (1.1.1–1.1.10) in the ANSWER BOOK, for example 1.1.11 D.
- 1.1.1 A/An ... insulator can be used to prevent a short circuit between the electric wires and the posts used for game fencing.
- A polyvinyl chloride
 - B aluminium
 - C paper
 - D brass
- 1.1.2 Safety signs fastened to an electrified fence must be ...
- A clearly visible to pedestrians.
 - B made of cardboard.
 - C made of plastic with a yellow background.
 - D earthed when made of metal.
- 1.1.3 The process whereby household water is sent through two different liquids separated by a permeable film. This film allows water to pass through on molecular level:
- A Distillation
 - B Evapotranspiration
 - C Filtration
 - D Reverse osmosis
- 1.1.4 A GPS device shows the correct position, accurate within a square metre of where you are on Earth.
- The abbreviation *GPS* stands for ...
- A geographical positioning system.
 - B grid positioning system.
 - C global positioning system.
 - D general positioning system.
- 1.1.5 Which ONE of the following power take-off safety precautions is wrong and does NOT fit in with the rest?
- A Stop the power take-off before dismounting the tractor.
 - B Always use the power take-off shaft at a 90° angle.
 - C Ensure that power take-off safety screens are in place before you start working.
 - D Replace cracked or defective power take-off safety screens immediately.

1.1.6 ONE of the following is a property of bronze:

- A Good resonant quality
- B Yellow colour
- C Spark-resistant mining components
- D Corrosion-resistant plumbing fittings

1.1.7 Annealing is a process used to ... metal.

- A magnetise
- B soften
- C electrify
- D harden

1.1.8 ... is NOT an adhesive:

- A Bostik
- B Cold glue
- C Bakelite
- D Silicon

1.1.9 The welding technique that can be successfully used to join two plates of 0,25 mm sheet metal:

- A Arc welding
- B Soft soldering
- C MIG welding
- D TIG welding

1.1.10 The ... gas must be opened first when lighting the flame of an oxyacetylene cutting torch.

- A oxygen
- B carbon dioxide
- C acetylene
- D argon

(10 x 2) (20)

1.2 Change the UNDERLINED word(s) in each of the following statements to make the statements TRUE. Write only the answer next to the question number (1.2.1–1.2.5) in the ANSWER BOOK, for example 1.2.6 Tractor.

1.2.1 Corrosion causes the metal from the melted pool to run down when doing vertical up MIG welding.

1.2.2 Carbon monoxide needs to be removed from the welding joint by means of a shielding gas when using the MIG welder.

1.2.3 The rotor converts the rotational energy into electrical energy in a wind turbine.

1.2.4 Fungi are the most important micro-organisms that ensure the effective working of the septic tank system.

1.2.5 Standardisation is the exact moment when the needles lift the binding rope to bind the compressed hay. (5 x 2)

(10)

1.3 Choose a word/term from COLUMN B that matches the description in COLUMN A. Write only the letter (A–G) next to the question number (1.3.1–1.3.5) in the ANSWER BOOK, for example 1.3.6 J.

COLUMN A		COLUMN B	
1.3.1	Captures large dust particles in the air filtration system of a tractor	A	three-point coupling
1.3.2	Inventor is Harry Ferguson	B	thermosiphon system
1.3.3	Facilitates the changing of gears in a tractor gearbox	C	synchronising unit
1.3.4	The most common cooling system	D	overdrive system
1.3.5	Ensures correct working of a diesel pump	E	calibration
		F	pre-cleaner
		G	draw bar

(5 x 2)

(10)

TOTAL SECTION A: 40

SECTION B**QUESTION 2: MATERIALS AND STRUCTURES**

Start this question on a **NEW** page.

2.1 The properties of a base metal can be changed for specific uses by adding certain alloy elements.

2.1.1 Name THREE alloy elements that are found in stainless steel. (3)

2.1.2 Name the alloy element that has a silvery white colour, is soft, malleable and resistant to oxygen and water, but dissolves in acids and bases. (1)

2.1.3 Name TWO alloy elements that are used to manufacture brass. (2)

2.2 Provide the type of material in the table below that can be used to manufacture the given products. Write only the answer next to the question number (2.2.1–2.2.6) in the ANSWER BOOK, for example 2.2.7 Nickel.

PRODUCT	MATERIAL
Hot-water pipes for a milking parlour	2.2.1
Plumbing fittings	2.2.2
Cans for processed food	2.2.3
Fishing rods	2.2.4
Non-metal bushes	2.2.5
Coating for non-stick pans	2.2.6

(6 x 1) (6)

2.3 The photograph below shows an electric fence on a farm. The voltage in the fence is 10 000 volts.



2.3.1 Name FOUR prescribed requirements for the warning signs that are placed on electric fences. (4)

- 2.3.2 Name TWO aspects that must be checked daily when inspecting an electric fence. (2)
- 2.3.3 List FOUR components of the movable electric fence system used to control animals in a specific area. (4)
- 2.4 Fibreglass can be used to manufacture water troughs for animals.
- 2.4.1 Name FIVE characteristics of fibreglass which will make troughs made of fibreglass more preferable than metal troughs. (5)
- 2.4.2 Give ONE reason why the catalyst and accelerator of fibreglass should be stored separately. (1)
- 2.5 State TWO aspects that must be considered when selecting an adhesive. (2)
- 2.6 Give an example of a hazardous chemical liquid found in the battery of a tractor. (1)
- 2.7 Name the THREE components needed for a fire to burn. (3)
- 2.8 While soldering a brass fitting, you overheat the fitting by mistake.
- Name a process that you can apply to relieve the internal stress in the brass fitting caused by overheating, without losing the properties of the brass fitting. (1)
- [35]**

QUESTION 3: ENERGY

Start this question on a **NEW** page.

- 3.1 The increased use of alternative energy systems has reduced the demand for the supply of electricity in South Africa.
- 3.1.1 Name TWO types of energy that apply to wind energy systems. (2)
- 3.1.2 How can the rotor of a wind turbine be protected from rotating too fast during a strong wind storm? (1)
- 3.1.3 Explain the concept *integration* with regard to alternative energy sources. (1)
- 3.1.4 Describe the process that takes place in the solar panel when producing electricity from solar energy. (4)
- 3.1.5 Give THREE reasons why a solar panel does not function to its full potential. (3)
- 3.1.6 Name the component that can be connected to a solar panel system to store generated energy to be used when sunlight is not available. (1)
- 3.1.7 State TWO advantages of solar energy. (2)
- 3.2 Study the picture below that illustrates a geothermal energy source and answer the questions that follow.

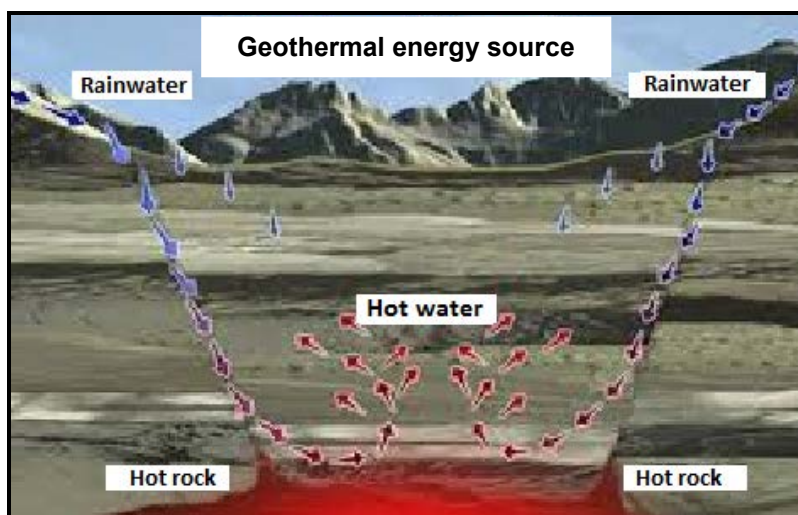

- 3.2.1 Explain what will happen to a geothermal energy source when you pump too much cold water into the source. (1)
- 3.2.2 State THREE factors that must be considered when choosing a suitable location for the extraction of geothermal energy. (3)
- 3.3 Manufacturing biodiesel from vegetable oils involves the process of transesterification of fatty acids.
- Name TWO plants that are suitable for this process. (2)

[20]

QUESTION 4: SKILLS AND CONSTRUCTION PROCESSES

Start this question on a NEW page.

4.1 Study the pictures below and provide an applicable accident-preventing safety regulation for each given situation.

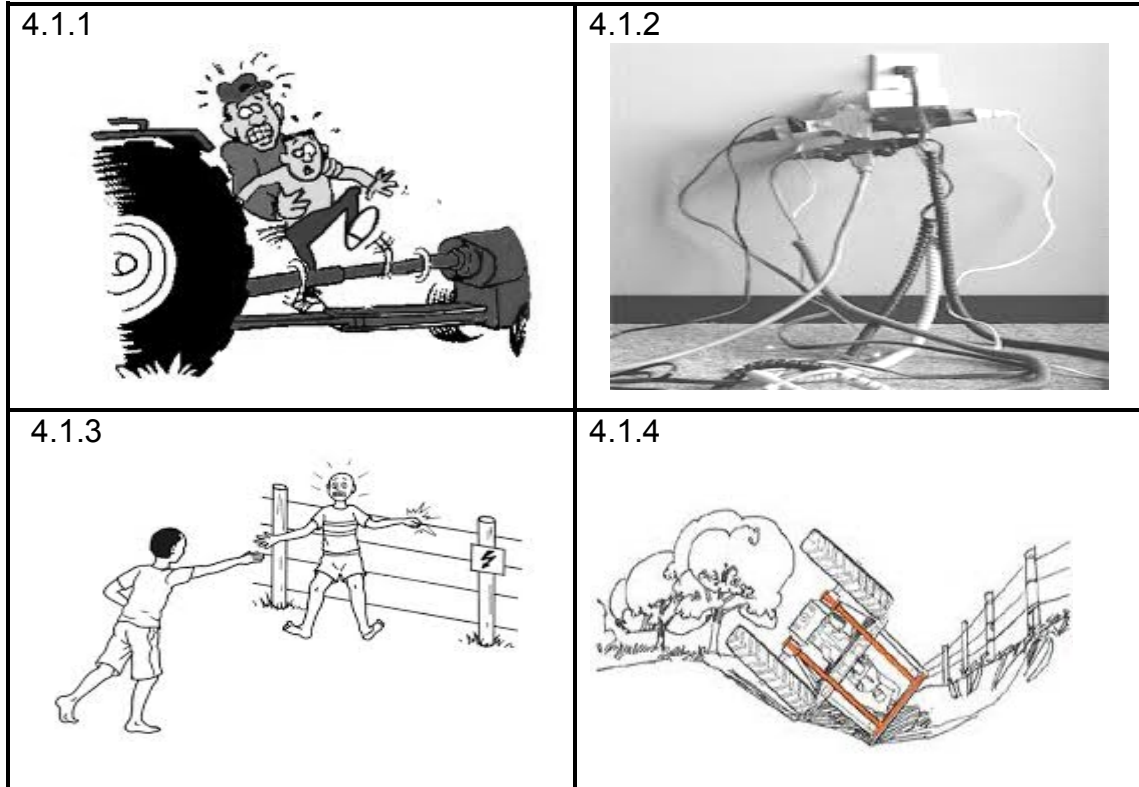

(4)

4.2 Briefly describe the *plasma-cutting process* using the machine in the photograph below.



(5)

4.3 Study the MIG welding nozzle below and answer the questions.

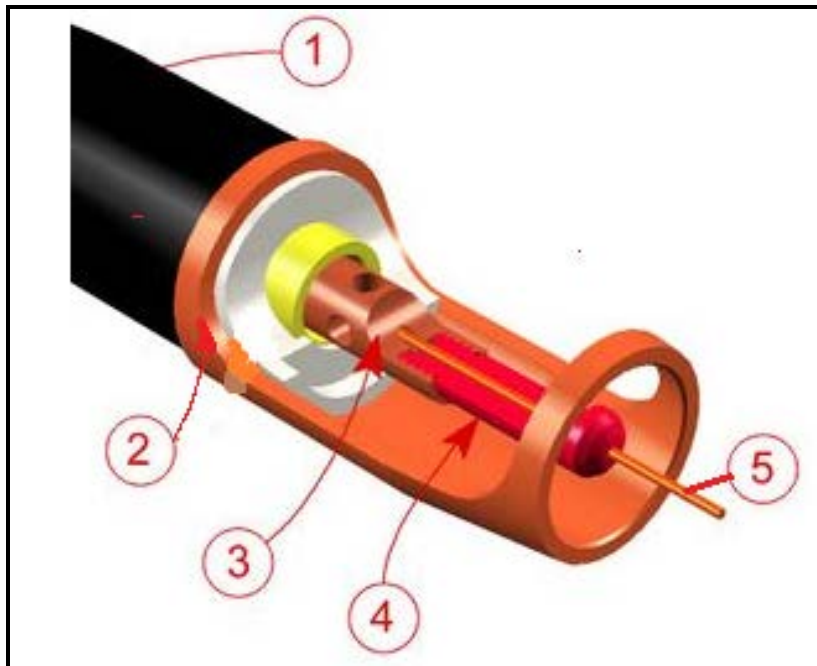

4.3.1 Label parts 1, 2, 3, 4 and 5 in the picture above. (5)

4.3.2 Name THREE different metals that can be welded successfully with this type of welding machine. (3)

4.3.3 State THREE advantages of the MIG welding machine. (3)

4.4 Describe the oxyacetylene cutting process when a 20 mm thick mild steel plate has to be cut. (6)

4.5 Refer to the illustration of a square butt joint below and answer the questions that follow.

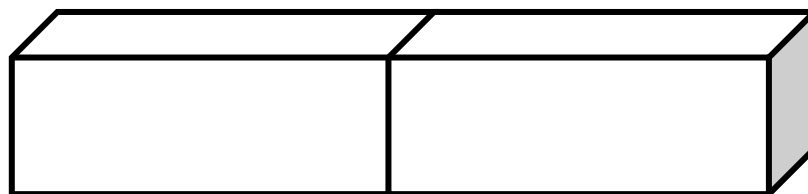

4.5.1 Describe the arc welding procedure when welding a butt weld joint. (7)

4.5.2 Name TWO types of shrinking that can occur in the butt-welding joint during welding. (2)
[35]

QUESTION 5: TOOLS, IMPLEMENTS AND EQUIPMENT

Start this question on a NEW page.

5.1 Identify the safety mechanism indicated by arrow **A** in the drawings below.

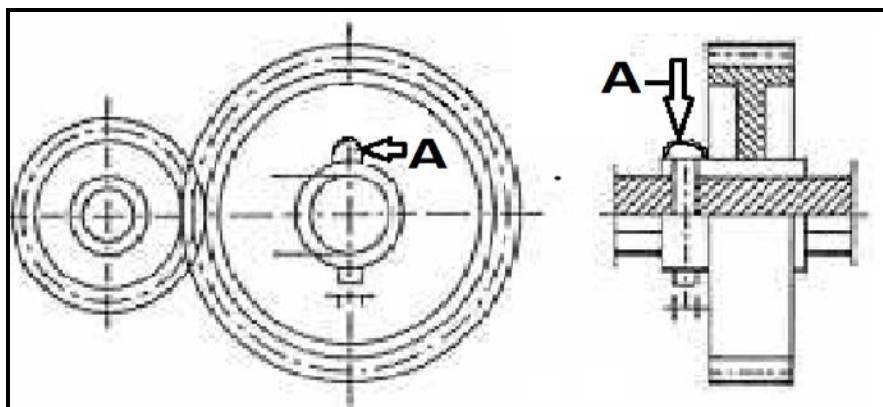

(1)

5.2 The picture below shows an implement which is connected to the three-point mechanism of a tractor for raking hay into windrows.

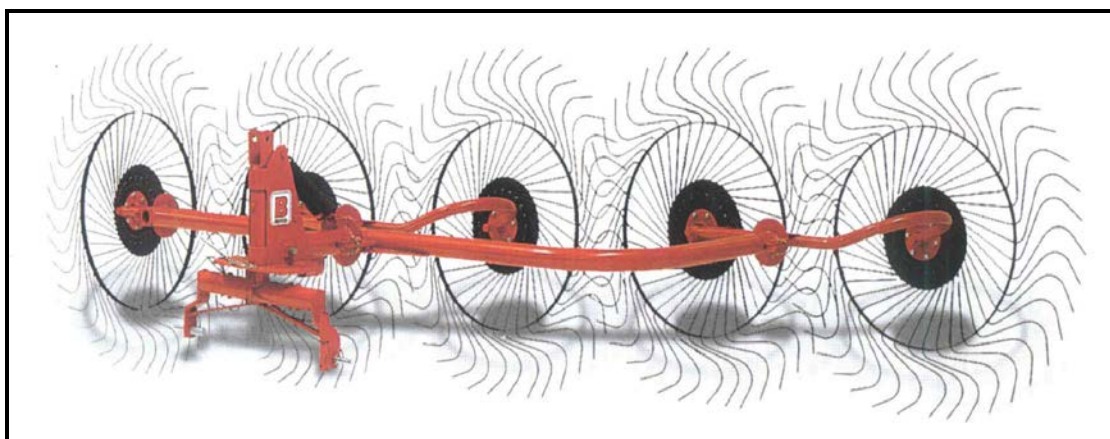

5.2.1 Name the component that is used on the three-point mechanism of the tractor that will prevent the implement from swinging sideways when it is being used. (1)

5.2.2 Which mechanism must be adjusted to set the horizontal levelness of the implement? (1)

5.2.3 Name the component on the tractor where the cross angle of the implement can be adjusted in relation to the tractor. (1)

5.2.4 State THREE maintenance procedures that must be followed when the hay rake is stored for a long period. (3)

5.3 Name TWO types of baling machines and identify the type of bales that EACH machine produces. (4)

5.4 Refer to the sketch below and answer the questions that follow.

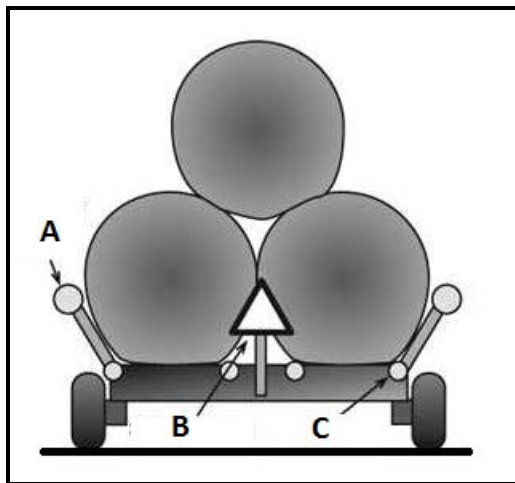

5.4.1 Name components **A**, **B** and **C** in the sketch above. (3)

5.4.2 State THREE circumstances under which it is advisable NOT to drive on a public road with an abnormally wide load on the trailer. (3)

5.5 Identify THREE mechanical problems that can occur during the use of a combine harvester. (3)

5.6 State THREE major causes of metal fatigue on a hammer mill. (3)

5.7 Name the component on a tractor that activates the control valve of the hydraulic system. (1)

5.8 Study the illustration of a pulley system below and answer the questions that follow.

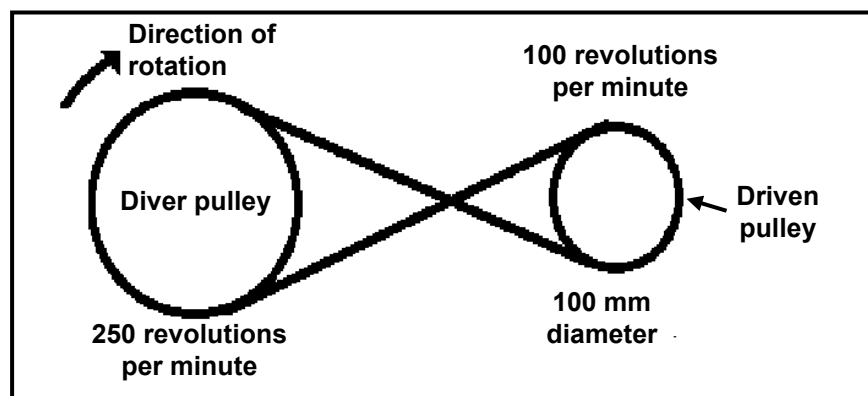

5.8.1 Calculate the diameter of the drive pulley if it turns at 25 revolutions per minute and the driven pulley turns at 100 revolutions per minute. The driven pulley has a diameter of 100 mm. Show ALL calculations.

Use the formula: $N_a \times D_a = N_g \times D_g$ (3)

5.8.2 Determine the turning direction of the driven pulley if the V-belt is crossed as indicated in the drawing above. (1)

5.8.3 State THREE disadvantages of using V-belts in drive systems. (3)

5.9 Buying a tractor is a huge financial expenditure and thorough research should be done before the purchase.

Name THREE factors to consider before purchasing a new tractor. (3)

5.10 State TWO advantages of mechanisation for agriculture. (2)

5.11 The photographs below show tools used in a workshop.

Indicate whether EACH tool (**A**, **B**, **C** and **D**) is either pneumatic or hydraulic.

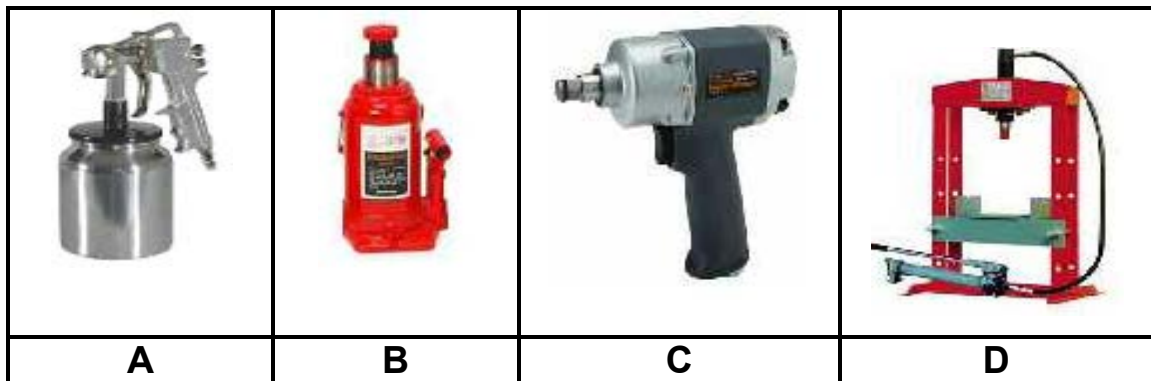

(4)
[40]

QUESTION 6: WATER MANAGEMENT

Start this question on a NEW page.

- 6.1 A drip line irrigation system used to supply a small amount of water through small holes in pipes to individual plants, is shown in the photograph below.



- 6.1.1 Name an impurity that could be present in the water, which will make this irrigation method inefficient. (1)
- 6.1.2 Suggest a possible solution to overcome the problem described in QUESTION 6.1.1. (1)

- 6.2 The centre-pivot irrigation system below needs high water pressure to work effectively.



- 6.2.1 State TWO effective methods that can be used to produce higher water pressure in the irrigation system above. (2)
- 6.2.2 Explain the importance of high water pressure for the effective working of this irrigation system. (2)
- 6.2.3 Give a practical example of the use of solar energy in an irrigation system. (1)

- 6.3 The hosepipe used in a subsistence farmer's vegetable garden supplies 100 litres of water per minute when two sprayers are connected to it.
- 6.3.1 Determine the amount of water that will be delivered by one sprayer in 5 minutes. (2)
- 6.3.2 Calculate the amount of water that 1 m² of soil will receive in 5 minutes if one sprayer irrigates 5 m². (2)
- 6.3.3 Give TWO reasons why a farmer should determine the flow rate of a pipe delivery system. (2)
- 6.4 It is important to determine if the supply of irrigation water is sufficient.
State TWO methods that can be used to measure the soil moisture content. (2)
- 6.5 The illustration below shows a septic tank that is used on a farm for the treatment of raw sewerage.

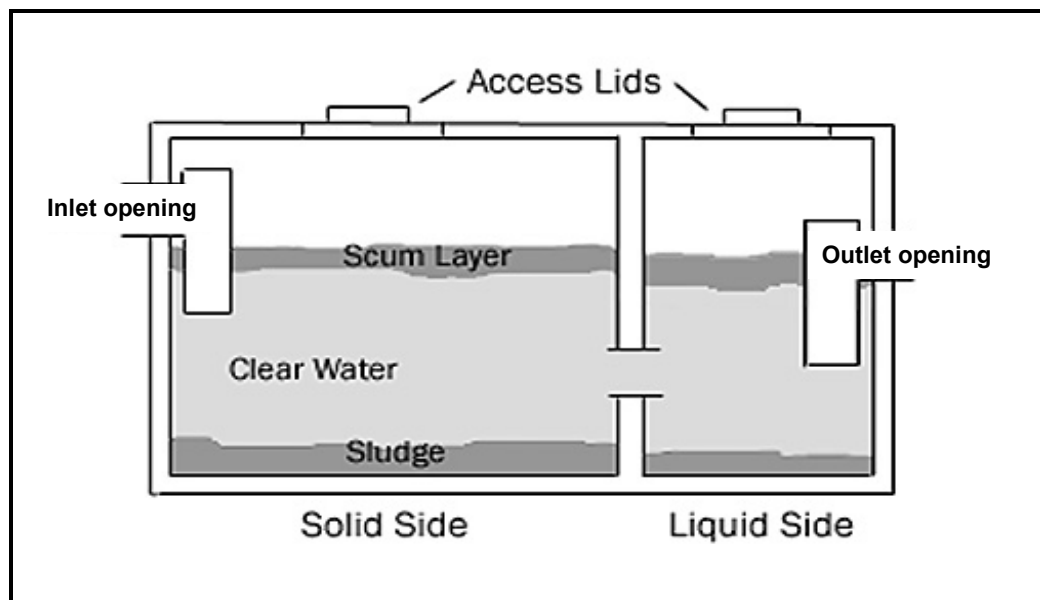

- 6.5.1 Give TWO reasons why the outlet opening in the septic tank is lower than the inlet opening. (2)
- 6.5.2 Explain the reason for not allowing water from the kitchen sink to enter the septic tank. (2)
- 6.5.3 Name TWO drainage systems that are commonly used for the disposal of kitchen waste water. (2)
- 6.5.4 Describe what happens with the solid waste particles at the bottom of the septic tank. (2)
- 6.5.5 State TWO aspects that a farmer must consider when deciding where to build a septic tank. (2)

- 6.6 Describe the way in which the whole-house water purification system functions. (3)
- 6.7 Name TWO materials that can be used to manufacture the sprinkler head in the picture below.

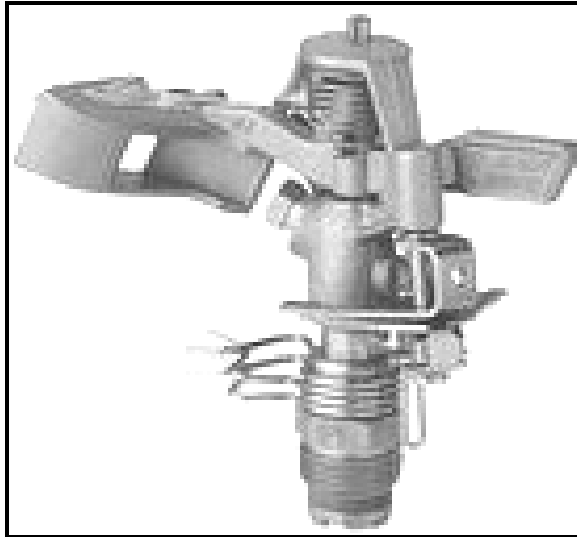

(2)
[30]

TOTAL SECTION B: 160
GRAND TOTAL: 200