



basic education

Department:
Basic Education
REPUBLIC OF SOUTH AFRICA

**NATIONAL
SENIOR CERTIFICATE**

GRADE 12

PHSC.2

PHYSICAL SCIENCES: CHEMISTRY (P2)

NOVEMBER 2014

MARKS: 150

TIME: 3 hours

This question paper consists of 16 pages and 4 data sheets.

MORNING SESSION



INSTRUCTIONS AND INFORMATION

1. Write your examination number and centre number in the appropriate spaces on the ANSWER BOOK.
2. This question paper consists of TEN questions. Answer ALL the questions in the ANSWER BOOK.
3. Start EACH question on a NEW page in the ANSWER BOOK.
4. Number the answers correctly according to the numbering system used in this question paper.
5. Leave ONE line between two subquestions, for example between QUESTION 2.1 and QUESTION 2.2.
6. You may use a non-programmable calculator.
7. You may use appropriate mathematical instruments.
8. You are advised to use the attached DATA SHEETS.
9. Show ALL formulae and substitutions in ALL calculations.
10. Round off your final numerical answers to a minimum of TWO decimal places.
11. Give brief motivations, discussions, et cetera where required.
12. Write neatly and legibly.



QUESTION 1: MULTIPLE-CHOICE QUESTIONS

Four options are provided as possible answers to the following questions. Each question has only ONE correct answer. Write only the letter (A–D) next to the question number (1.1–1.10) in the ANSWER BOOK, for example 1.11. D.

- 1.1 Which ONE of the following is a primary nutrient for plants?
- A Oxygen
 - B Carbon
 - C Potassium
 - D Magnesium (2)
- 1.2 Which ONE of the following statements is CORRECT?
- Alkenes ...
- A have the general formula C_nH_{2n+2} .
 - B are unsaturated hydrocarbons.
 - C readily undergo substitution reactions.
 - D have one triple bond between two carbon atoms. (2)
- 1.3 Consider the reaction represented by the balanced equation below:
- $$Cu(s) + 2Ag^+(aq) \rightarrow Cu^{2+}(aq) + 2Ag(s)$$
- In the above reaction, Cu(s) is the ...
- A oxidising agent and is reduced.
 - B oxidising agent and is oxidised.
 - C reducing agent and is reduced.
 - D reducing agent and is oxidised. (2)

- 1.4 Which ONE of the following describes the effect of a positive catalyst on the net activation energy and the heat of reaction (ΔH) of a specific reaction?

	NET ACTIVATION ENERGY	ΔH
A	Increases	No effect
B	Decreases	Increases
C	No effect	Decreases
D	Decreases	No effect

(2)

- 1.5 The following equation represents the cracking of a hydrocarbon at high temperature and pressure:

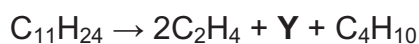

Which ONE of the following is the IUPAC name of product Y?

- A Prop-1-ene
- B Propane
- C Ethene
- D Ethane

(2)

- 1.6 When 2-chlorobutane is strongly heated in the presence of concentrated sodium hydroxide, the major product formed is ...

- A but-1-ene.
- B but-2-ene.
- C butan-1-ol.
- D butan-2-ol.

(2)



- 1.7 A hypothetical reaction reaches equilibrium at 10 °C in a closed container according to the following balanced equation:

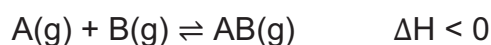

The temperature is now increased to 25 °C. Which ONE of the following is correct as the reaction approaches a new equilibrium?

	REACTION RATE	YIELD OF PRODUCTS
A	Increases	Remains the same
B	Increases	Decreases
C	Increases	Increases
D	Decreases	Decreases

(2)

- 1.8 Which ONE of the following represents the products formed during the hydrolysis of ammonium chloride?

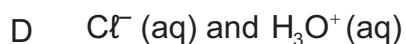
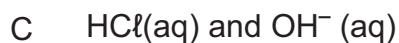
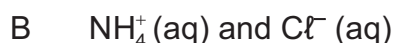
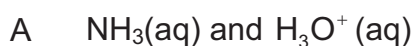

(2)

- 1.9 An electrochemical cell is used to electroplate an iron spoon with nickel.

Which ONE of the following half-reactions takes place at the positive electrode of this cell?

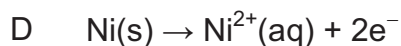
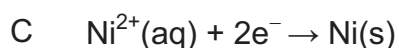
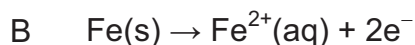
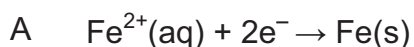

(2)



- 1.10 The following reaction reaches equilibrium in a closed container at a certain temperature:

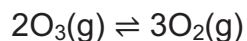

The pressure is now decreased by increasing the volume of the container at constant temperature.

Which ONE of the following is correct as the reaction approaches a new equilibrium?

	NUMBER OF MOLES OF $\text{O}_3(\text{g})$	NUMBER OF MOLES OF $\text{O}_2(\text{g})$	CONCENTRATION OF $\text{O}_2(\text{g})$
A	Increases	Decreases	Decreases
B	Decreases	Increases	Increases
C	Decreases	Increases	Decreases
D	Increases	Decreases	Increases

(2)
[20]

QUESTION 2 (Start on a new page.)

Consider the organic compounds represented by the letters **A** to **F** in the table below.

A	2,2,4-trimethylhexane	B	$\text{CH}_3\text{CH}_2\text{CH}_2\text{CH}_2\text{CHO}$
C	$ \begin{array}{cccccc} & \text{H} & \text{H} & \text{Cl} & \text{Br} & \text{H} \\ & & & & & \\ \text{H} & -\text{C} & -\text{C} & -\text{C} & -\text{C} & -\text{C}-\text{H} \\ & & & & & \\ & \text{H} & & \text{H} & \text{H} & \text{H} \\ & & & & & \\ & & \text{H}-\text{C}-\text{H} & & & \\ & & & & & \\ & & \text{H} & & & \end{array} $	D	$ \left(\begin{array}{cc} \text{H} & \text{H} \\ & \\ -\text{C} & -\text{C}- \\ & \\ \text{H} & \text{H} \end{array} \right)_n $
E	$ \left(\begin{array}{cccccc} & \text{H} & \text{H} & & \text{O} & \text{H} & \text{O} \\ & & & & & & \\ -\text{O} & -\text{C} & -\text{C} & -\text{O} & -\text{C} & -\text{C} & -\text{C}- \\ & & & & & & \\ & \text{H} & \text{H} & & & \text{H} & \end{array} \right)_n $	F	Pentan-2-one

- 2.1 Write down the LETTER that represents the following:
- 2.1.1 An aldehyde (1)
- 2.1.2 A condensation polymer (1)
- 2.1.3 A compound which has a carbonyl group bonded to two carbon atoms as its functional group (1)
- 2.2 Write down the IUPAC name of:
- 2.2.1 Compound **C** (3)
- 2.2.2 The monomer of compound **D** (1)
- 2.3 Write down the structural formula of:
- 2.3.1 Compound **A** (2)
- 2.3.2 Compound **F** (2)
- 2.4 The table contains compounds which are functional isomers.
- 2.4.1 Define the term *functional isomer*. (2)
- 2.4.2 Write down the LETTERS that represent two compounds that are functional isomers. (1)

[14]

QUESTION 3 (Start on a new page.)

- 3.1 Give a reason why alkanes are *saturated* hydrocarbons. (1)
- 3.2 Write down the structural formula of:
- 3.2.1 The functional group of alcohols (1)
- 3.2.2 A tertiary alcohol that is a structural isomer of butan-1-ol (2)
- 3.3 Learners investigate factors that influence the boiling points of alkanes and alcohols. In one of the investigations they determine the boiling points of the first three alkanes.
- 3.3.1 Write down an investigative question for this investigation. (2)
- 3.3.2 Fully explain why the boiling point increases from methane to propane. (3)
- 3.4 The learners find that the boiling point of propan-1-ol is higher than that of propane.
- Explain this observation by referring to the TYPE of INTERMOLECULAR FORCES present in each of these compounds. (3)
- [12]**

QUESTION 4 (Start on a new page.)

The flow diagram below shows the preparation of an ester using prop-1-ene as a starting reagent. **P**, **Q**, **R** and **S** represent different organic reactions.

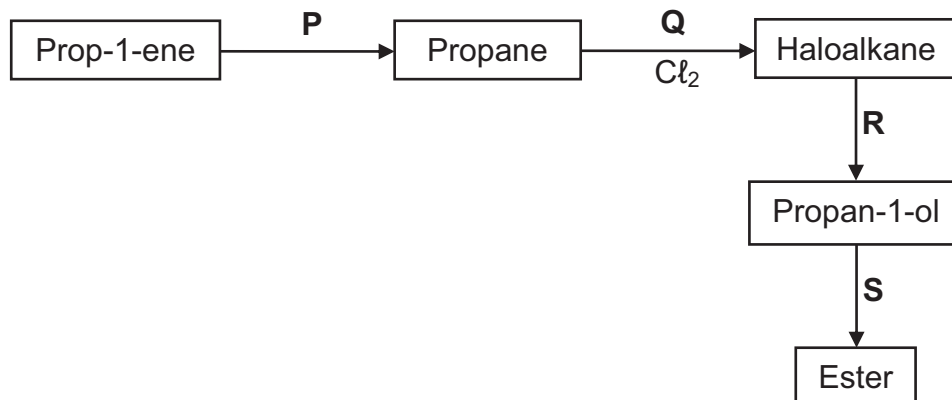

- 4.1 Write down the type of reaction represented by:
- 4.1.1 **Q** (1)
- 4.1.2 **R** (1)
- 4.2 For reaction **P** write down the:
- 4.2.1 Type of addition reaction (1)
- 4.2.2 Balanced equation using structural formulae (3)
- 4.3 Write down the structural formula of the haloalkane formed in reaction **Q**. (2)
- 4.4 In reaction **S** propan-1-ol reacts with ethanoic acid to form the ester.
- For this reaction write down the:
- 4.4.1 Name of the reaction that takes place (1)
- 4.4.2 FORMULA or NAME of the catalyst needed (1)
- 4.4.3 Structural formula of the ester formed (2)
- 4.4.4 IUPAC name of the ester formed (2)
- 4.5 The propan-1-ol formed in reaction **R** can be converted to prop-1-ene. Write down the FORMULA or NAME of the inorganic reagent needed. (1)
- [15]**



QUESTION 5 (Start on a new page.)

5.1 Define the term *reaction rate* in words. (2)

Learners use the reaction between IMPURE POWDERED calcium carbonate and excess hydrochloric acid to investigate reaction rate. The balanced equation for the reaction is:



They perform four experiments under different conditions of concentration, mass and temperature as shown in the table below. They use identical apparatus in the four experiments and measure the volume of gas released in each experiment.

	EXPERIMENT			
	1	2	3	4
Concentration of acid ($\text{mol}\cdot\text{dm}^{-3}$)	1	0,5	1	1
Mass of impure calcium carbonate (g)	15	15	15	25
Initial temperature of acid ($^{\circ}\text{C}$)	30	30	40	40

5.2 The results of experiments **1** and **3** are compared in the investigation.

Write down the:

5.2.1 Independent variable (1)

5.2.2 Dependent variable (1)

5.3 Use the collision theory to explain why the reaction rate in experiment **4** will be higher than that in experiment **3**. (3)

The learners obtain graphs **A**, **B**, **C** and **D** below from their results.

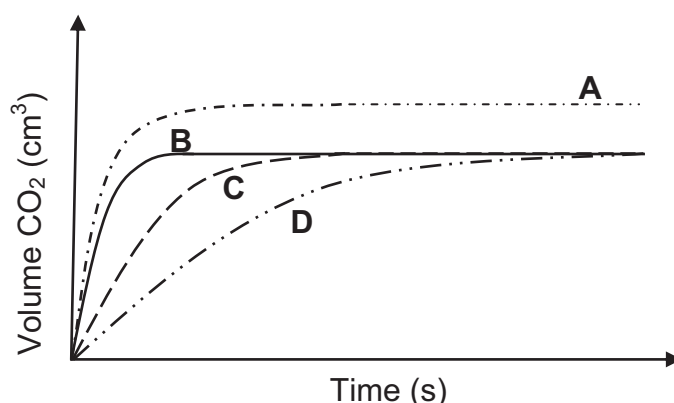

5.4 Which ONE of the graphs (**A**, **B**, **C** or **D**) represents experiment **1**? Fully explain the answer by comparing experiment **1** with experiments **2**, **3** and **4**. (6)

5.5 When the reaction in experiment **4** reaches completion, the volume of gas formed is $4,5 \text{ dm}^3$. Assume that the molar gas volume at 40°C is equal to $25,7 \text{ dm}^3$.

Calculate the mass of the impurities present in the calcium carbonate. (5)
[18]

QUESTION 6 (Start on a new page.)

A certain amount of nitrogen dioxide gas (NO_2) is sealed in a gas syringe at $25\text{ }^\circ\text{C}$. When equilibrium is reached, the volume occupied by the reaction mixture in the gas syringe is 80 cm^3 . The balanced chemical equation for the reaction taking place is:

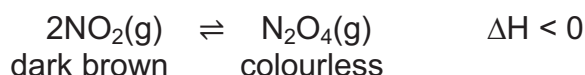

6.1 Define the term *chemical equilibrium*. (2)

6.2 At equilibrium the concentration of the $\text{NO}_2(\text{g})$ is $0,2\text{ mol}\cdot\text{dm}^{-3}$. The equilibrium constant for the reaction is 171 at $25\text{ }^\circ\text{C}$.

Calculate the initial number of moles of $\text{NO}_2(\text{g})$ placed in the gas syringe. (8)

6.3 The diagram below shows the reaction mixture in the gas syringe after equilibrium is established.



The pressure is now increased by decreasing the volume of the gas syringe at constant temperature as illustrated in the diagram below.



6.3.1 IMMEDIATELY after increasing the pressure, the colour of the reaction mixture in the gas syringe appears darker than before. Give a reason for this observation. (1)

After a while a new equilibrium is established as illustrated below. The colour of the reaction mixture in the gas syringe now appears lighter than the initial colour.



6.3.2 Use Le Chatelier's principle to explain the colour change observed in the gas syringe. (3)

6.4 The temperature of the reaction mixture in the gas syringe is now increased and a new equilibrium is established. How will each of the following be affected?

6.4.1 Colour of the reaction mixture
Write down only DARKER, LIGHTER or REMAINS THE SAME. (1)

6.4.2 Value of the equilibrium constant (K_c)
Write down only INCREASES, DECREASES or REMAINS THE SAME. (1)

[16]



QUESTION 7 (Start on a new page.)

- 7.1 Nitric acid (HNO_3), an important acid used in industry, is a strong acid.
- 7.1.1 Give a reason why nitric acid is classified as a strong acid. (1)
- 7.1.2 Write down the NAME or FORMULA of the conjugate base of nitric acid. (1)
- 7.1.3 Calculate the pH of a $0,3 \text{ mol}\cdot\text{dm}^{-3}$ nitric acid solution. (3)
- 7.2 A laboratory technician wants to determine the percentage purity of magnesium oxide. He dissolves a $4,5 \text{ g}$ sample of the magnesium oxide in 100 cm^3 hydrochloric acid of concentration $2 \text{ mol}\cdot\text{dm}^{-3}$.
- 7.2.1 Calculate the number of moles of hydrochloric acid added to the magnesium oxide. (3)

He then uses the apparatus below to titrate the EXCESS hydrochloric acid in the above solution against a sodium hydroxide solution.

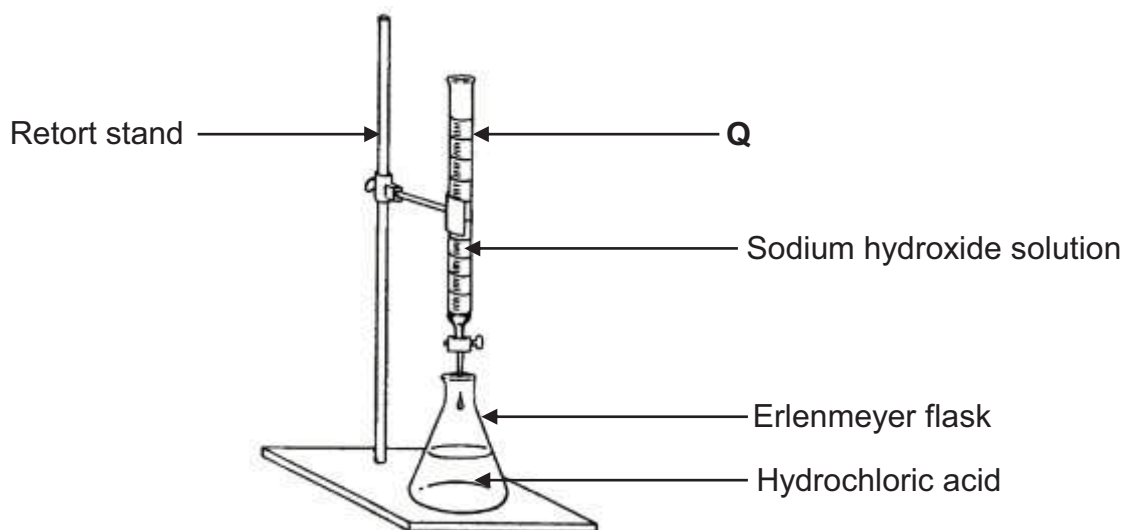

- 7.2.2 Write down the name of apparatus **Q** in the above diagram. (1)
- 7.2.3 The following indicators are available for the titration:

INDICATOR	pH RANGE
A	3,1 – 4,4
B	6,0 – 7,6
C	8,3 – 10,0

Which ONE of the above indicators (**A**, **B** or **C**) is most suitable to indicate the exact endpoint in this titration? Give a reason for the answer. (3)

7.2.4 During the titration, the technician uses distilled water to wash any sodium hydroxide spilled against the sides of the Erlenmeyer flask into the solution.

Give a reason why the addition of distilled water to the Erlenmeyer flask will not influence the results.

(1)

7.2.5 At the endpoint of the titration he finds that 21 cm^3 of a $0,2 \text{ mol dm}^{-3}$ sodium hydroxide solution has neutralised the EXCESS hydrochloric acid.

Calculate the number of moles of hydrochloric acid in excess.

(3)

7.2.6 The balanced equation for the reaction between hydrochloric acid and magnesium oxide is:

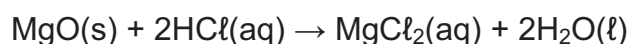

Calculate the percentage purity of the magnesium oxide. Assume that only the magnesium oxide in the 4,5 g sample reacted with the acid.

(5)

[21]



QUESTION 8 (Start on a new page.)

A standard electrochemical cell is set up using a standard hydrogen half-cell and a standard $X|X^{2+}$ half-cell as shown below. A voltmeter connected across the cell, initially registers 0,31 V.

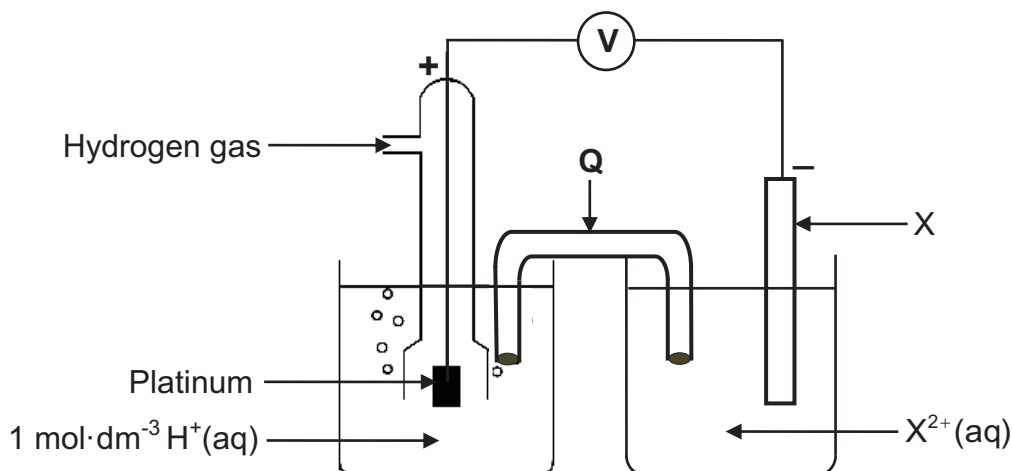

- 8.1 Besides concentration write down TWO conditions needed for the hydrogen half-cell to function under standard conditions. (2)
- 8.2 Give TWO reasons, besides being a solid, why platinum is suitable to be used as electrode in the above cell. (2)
- 8.3 Write down the:
- 8.3.1 NAME of component Q (1)
- 8.3.2 Standard reduction potential of the $X|X^{2+}$ half-cell (1)
- 8.3.3 Half-reaction that takes place at the cathode of this cell (2)
- 8.4 The hydrogen half-cell is now replaced by a $M|M^{2+}$ half-cell. The cell notation of this cell is:



The initial reading on the voltmeter is now 2,05 V.

- 8.4.1 Identify metal **M**. Show how you arrived at the answer. (5)
- 8.4.2 Is the cell reaction EXOTHERMIC or ENDOTHERMIC? (1)
- 8.5 The reading on the voltmeter becomes zero after using this cell for several hours. Give a reason for this reading by referring to the cell reaction. (1)

[15]

QUESTION 9 (Start on a new page.)

The simplified diagrams below represent two electrochemical cells, **A** and **B**. A concentrated copper(II) chloride solution is used as electrolyte in both cells.

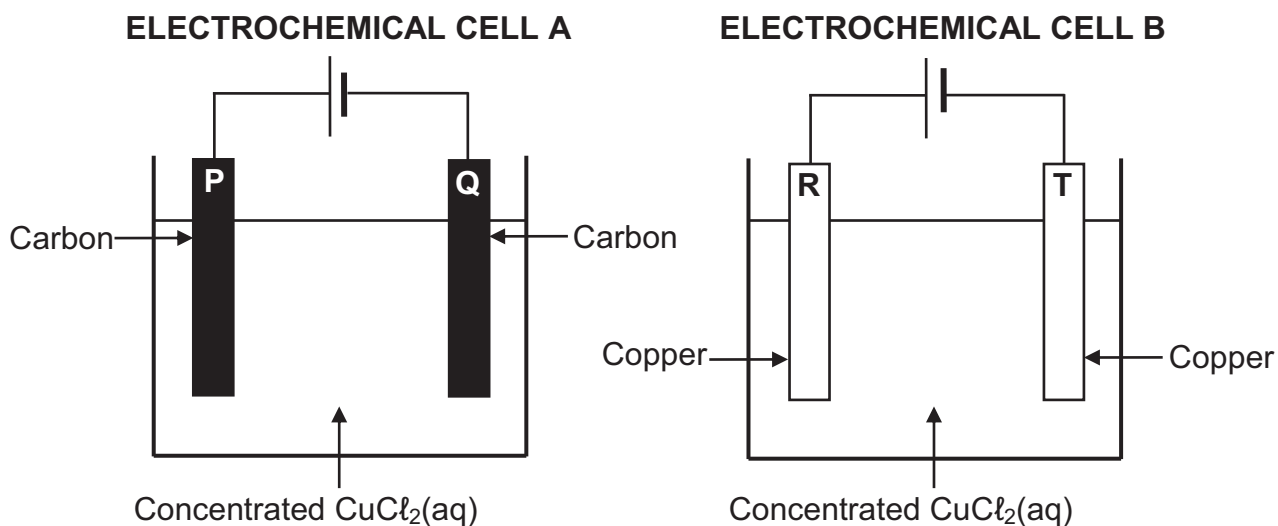

- 9.1 Are **A** and **B** ELECTROLYTIC or GALVANIC cells? (1)
- 9.2 Which of the electrodes (**P**, **Q**, **R** or **T**) will show a mass increase? Write down a half-reaction to motivate the answer. (4)
- 9.3 Write down the NAME or FORMULA of the product formed at:
- 9.3.1 Electrode **P** (1)
- 9.3.2 Electrode **R** (1)
- 9.4 Fully explain the answer to QUESTION 9.3.2 by referring to the relative strengths of the reducing agents involved. (3)
- [10]**

QUESTION 10 (Start on a new page.)

- 10.1 The flow diagram below shows the processes involved in the industrial preparation of fertiliser **Q**.

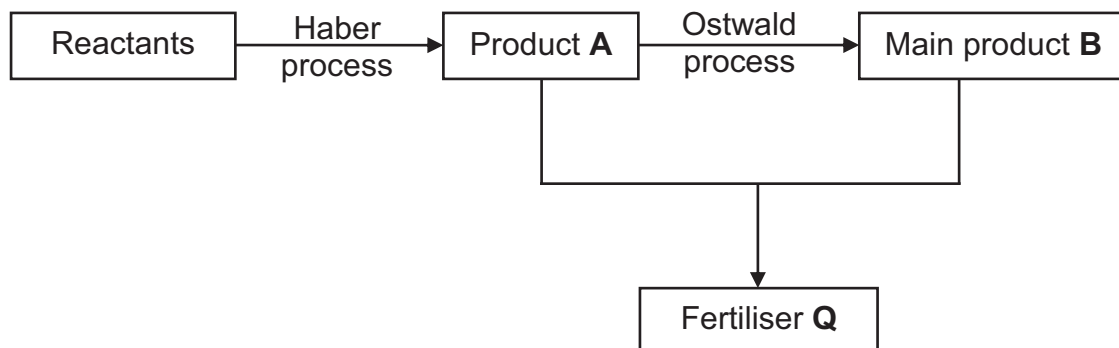

Write down the:

- 10.1.1 NAMES or FORMULAE of the reactants used in the Haber process (2)
- 10.1.2 Balanced equation for the formation of fertiliser **Q** (3)
- 10.2 The diagram below shows a bag of NPK fertiliser.



Calculate the mass of nitrogen in the bag.

(4)
[9]

TOTAL: 150

**DATA FOR PHYSICAL SCIENCES GRADE 12
PAPER 2 (CHEMISTRY)**

**GEGEWENS VIR FISIESTE WETENSKAPPE GRAAD 12
VRAESTEL 2 (CHEMIE)**

TABLE 1: PHYSICAL CONSTANTS/TABEL 1: FISIESTE KONSTANTES

NAME/NAAM	SYMBOL/SIMBOOL	VALUE/WAARDE
Standard pressure <i>Standaarddruk</i>	p^θ	$1,013 \times 10^5 \text{ Pa}$
Molar gas volume at STP <i>Molêre gasvolume by STD</i>	V_m	$22,4 \text{ dm}^3 \cdot \text{mol}^{-1}$
Standard temperature <i>Standaardtemperatuur</i>	T^θ	273 K
Charge on electron <i>Lading op elektron</i>	e	$-1,6 \times 10^{-19} \text{ C}$
Avogadro's constant <i>Avogadro-konstante</i>	N_A	$6,02 \times 10^{23} \text{ mol}^{-1}$

TABLE 2: FORMULAE/TABEL 2: FORMULES

$n = \frac{m}{M}$	$n = \frac{N}{N_A}$
$c = \frac{n}{V}$ or/of $c = \frac{m}{MV}$	$n = \frac{V}{V_m}$
$\frac{c_a v_a}{c_b v_b} = \frac{n_a}{n_b}$	$\text{pH} = -\log[\text{H}_3\text{O}^+]$
$K_w = [\text{H}_3\text{O}^+][\text{OH}^-] = 1 \times 10^{-14}$ at/by 298 K	
$E_{\text{cell}}^\theta = E_{\text{cathode}}^\theta - E_{\text{anode}}^\theta$ / $E_{\text{sel}}^\theta = E_{\text{katode}}^\theta - E_{\text{anode}}^\theta$	
or/of	
$E_{\text{cell}}^\theta = E_{\text{reduction}}^\theta - E_{\text{oxidation}}^\theta$ / $E_{\text{sel}}^\theta = E_{\text{reduksie}}^\theta - E_{\text{oksidasie}}^\theta$	
or/of	
$E_{\text{cell}}^\theta = E_{\text{oxidisingagent}}^\theta - E_{\text{reducingagent}}^\theta$ / $E_{\text{sel}}^\theta = E_{\text{oksideermiddel}}^\theta - E_{\text{reduseermiddel}}^\theta$	



TABLE 3: THE PERIODIC TABLE OF ELEMENTS
TABEL 3: DIE PERIODIEKE TABEL VAN ELEMENTE

1 (I)	2 (II)	3	4	5	6	7	8	9	10	11	12	13 (III)	14 (IV)	15 (V)	16 (VI)	17 (VII)	18 (VIII)
1 H 1																	2 He 4
3 Li 7	4 Be 9													7 N 14	8 O 16	9 F 19	10 Ne 20
11 Na 23	12 Mg 24												14 Si 28	15 P 31	16 S 32	17 Cl 35,5	18 Ar 40
19 K 39	20 Ca 40	21 Sc 45	22 Ti 48	23 V 51	24 Cr 52	25 Mn 55	26 Fe 56	27 Co 59	28 Ni 59	29 Cu 63,5	30 Zn 65	31 Ga 70	32 Ge 73	33 As 75	34 Se 79	35 Br 80	36 Kr 84
37 Rb 86	38 Sr 88	39 Y 89	40 Zr 91	41 Nb 92	42 Mo 96	43 Tc 98	44 Ru 101	45 Rh 103	46 Pd 106	47 Ag 108	48 Cd 112	49 In 115	50 Sn 119	51 Sb 122	52 Te 128	53 I 127	54 Xe 131
55 Cs 133	56 Ba 137	57 La 139	72 Hf 179	73 Ta 181	74 W 184	75 Re 186	76 Os 190	77 Ir 192	78 Pt 195	79 Au 197	80 Hg 201	81 Tl 204	82 Pb 207	83 Bi 209	84 Po 209	85 At 210	86 Rn 222
87 Fr 227	88 Ra 226	89 Ac															
				58 Ce 140	59 Pr 141	60 Nd 144	61 Pm	62 Sm 150	63 Eu 152	64 Gd 157	65 Tb 159	66 Dy 163	67 Ho 165	68 Er 167	69 Tm 169	70 Yb 173	71 Lu 175
				90 Th 232	91 Pa 231	92 U 238	93 Np 237	94 Pu 244	95 Am 243	96 Cm 247	97 Bk 247	98 Cf 251	99 Es 252	100 Fm 257	101 Md 288	102 No 289	103 Lr 260

KEYISLEUTEL
Atomic number
Atoomgetal

Electronegativity
Elektronegatiwiteit

Symbol
Simbool

Approximate relative atomic mass
Benaderde relatiewe atoommassa



TABLE 4A: STANDARD REDUCTION POTENTIALS
TABEL 4A: STANDAARDREDUKSIEPOTENSIALE

Half-reactions/Halfreaksies	E^{\ominus} (V)
$F_2(g) + 2e^- \rightleftharpoons 2F^-$	+ 2,87
$Co^{3+} + e^- \rightleftharpoons Co^{2+}$	+ 1,81
$H_2O_2 + 2H^+ + 2e^- \rightleftharpoons 2H_2O$	+1,77
$MnO_4^- + 8H^+ + 5e^- \rightleftharpoons Mn^{2+} + 4H_2O$	+ 1,51
$Cl_2(g) + 2e^- \rightleftharpoons 2Cl^-$	+ 1,36
$Cr_2O_7^{2-} + 14H^+ + 6e^- \rightleftharpoons 2Cr^{3+} + 7H_2O$	+ 1,33
$O_2(g) + 4H^+ + 4e^- \rightleftharpoons 2H_2O$	+ 1,23
$MnO_2 + 4H^+ + 2e^- \rightleftharpoons Mn^{2+} + 2H_2O$	+ 1,23
$Pt^{2+} + 2e^- \rightleftharpoons Pt$	+ 1,20
$Br_2(l) + 2e^- \rightleftharpoons 2Br^-$	+ 1,07
$NO_3^- + 4H^+ + 3e^- \rightleftharpoons NO(g) + 2H_2O$	+ 0,96
$Hg^{2+} + 2e^- \rightleftharpoons Hg(l)$	+ 0,85
$Ag^+ + e^- \rightleftharpoons Ag$	+ 0,80
$NO_3^- + 2H^+ + e^- \rightleftharpoons NO_2(g) + H_2O$	+ 0,80
$Fe^{3+} + e^- \rightleftharpoons Fe^{2+}$	+ 0,77
$O_2(g) + 2H^+ + 2e^- \rightleftharpoons H_2O_2$	+ 0,68
$I_2 + 2e^- \rightleftharpoons 2I^-$	+ 0,54
$Cu^+ + e^- \rightleftharpoons Cu$	+ 0,52
$SO_2 + 4H^+ + 4e^- \rightleftharpoons S + 2H_2O$	+ 0,45
$2H_2O + O_2 + 4e^- \rightleftharpoons 4OH^-$	+ 0,40
$Cu^{2+} + 2e^- \rightleftharpoons Cu$	+ 0,34
$SO_4^{2-} + 4H^+ + 2e^- \rightleftharpoons SO_2(g) + 2H_2O$	+ 0,17
$Cu^{2+} + e^- \rightleftharpoons Cu^+$	+ 0,16
$Sn^{4+} + 2e^- \rightleftharpoons Sn^{2+}$	+ 0,15
$S + 2H^+ + 2e^- \rightleftharpoons H_2S(g)$	+ 0,14
$2H^+ + 2e^- \rightleftharpoons H_2(g)$	0,00
$Fe^{3+} + 3e^- \rightleftharpoons Fe$	- 0,06
$Pb^{2+} + 2e^- \rightleftharpoons Pb$	- 0,13
$Sn^{2+} + 2e^- \rightleftharpoons Sn$	- 0,14
$Ni^{2+} + 2e^- \rightleftharpoons Ni$	- 0,27
$Co^{2+} + 2e^- \rightleftharpoons Co$	- 0,28
$Cd^{2+} + 2e^- \rightleftharpoons Cd$	- 0,40
$Cr^{3+} + e^- \rightleftharpoons Cr^{2+}$	- 0,41
$Fe^{2+} + 2e^- \rightleftharpoons Fe$	- 0,44
$Cr^{3+} + 3e^- \rightleftharpoons Cr$	- 0,74
$Zn^{2+} + 2e^- \rightleftharpoons Zn$	- 0,76
$2H_2O + 2e^- \rightleftharpoons H_2(g) + 2OH^-$	- 0,83
$Cr^{2+} + 2e^- \rightleftharpoons Cr$	- 0,91
$Mn^{2+} + 2e^- \rightleftharpoons Mn$	- 1,18
$Al^{3+} + 3e^- \rightleftharpoons Al$	- 1,66
$Mg^{2+} + 2e^- \rightleftharpoons Mg$	- 2,36
$Na^+ + e^- \rightleftharpoons Na$	- 2,71
$Ca^{2+} + 2e^- \rightleftharpoons Ca$	- 2,87
$Sr^{2+} + 2e^- \rightleftharpoons Sr$	- 2,89
$Ba^{2+} + 2e^- \rightleftharpoons Ba$	- 2,90
$Cs^+ + e^- \rightleftharpoons Cs$	- 2,92
$K^+ + e^- \rightleftharpoons K$	- 2,93
$Li^+ + e^- \rightleftharpoons Li$	- 3,05

Increasing oxidising ability/Toenemende oksiderende vermoë

Increasing reducing ability/Toenemende reduserende vermoë



TABLE 4B: STANDARD REDUCTION POTENTIALS
TABEL 4B: STANDAARDREDUKSIEPOTENSIALE

Increasing oxidising ability/Toenemende oksiderende vermoë

Half-reactions/Halfreaksies	E^θ (V)
$\text{Li}^+ + \text{e}^- \rightleftharpoons \text{Li}$	- 3,05
$\text{K}^+ + \text{e}^- \rightleftharpoons \text{K}$	- 2,93
$\text{Cs}^+ + \text{e}^- \rightleftharpoons \text{Cs}$	- 2,92
$\text{Ba}^{2+} + 2\text{e}^- \rightleftharpoons \text{Ba}$	- 2,90
$\text{Sr}^{2+} + 2\text{e}^- \rightleftharpoons \text{Sr}$	- 2,89
$\text{Ca}^{2+} + 2\text{e}^- \rightleftharpoons \text{Ca}$	- 2,87
$\text{Na}^+ + \text{e}^- \rightleftharpoons \text{Na}$	- 2,71
$\text{Mg}^{2+} + 2\text{e}^- \rightleftharpoons \text{Mg}$	- 2,36
$\text{Al}^{3+} + 3\text{e}^- \rightleftharpoons \text{Al}$	- 1,66
$\text{Mn}^{2+} + 2\text{e}^- \rightleftharpoons \text{Mn}$	- 1,18
$\text{Cr}^{2+} + 2\text{e}^- \rightleftharpoons \text{Cr}$	- 0,91
$2\text{H}_2\text{O} + 2\text{e}^- \rightleftharpoons \text{H}_2(\text{g}) + 2\text{OH}^-$	- 0,83
$\text{Zn}^{2+} + 2\text{e}^- \rightleftharpoons \text{Zn}$	- 0,76
$\text{Cr}^{3+} + 3\text{e}^- \rightleftharpoons \text{Cr}$	- 0,74
$\text{Fe}^{2+} + 2\text{e}^- \rightleftharpoons \text{Fe}$	- 0,44
$\text{Cr}^{3+} + \text{e}^- \rightleftharpoons \text{Cr}^{2+}$	- 0,41
$\text{Cd}^{2+} + 2\text{e}^- \rightleftharpoons \text{Cd}$	- 0,40
$\text{Co}^{2+} + 2\text{e}^- \rightleftharpoons \text{Co}$	- 0,28
$\text{Ni}^{2+} + 2\text{e}^- \rightleftharpoons \text{Ni}$	- 0,27
$\text{Sn}^{2+} + 2\text{e}^- \rightleftharpoons \text{Sn}$	- 0,14
$\text{Pb}^{2+} + 2\text{e}^- \rightleftharpoons \text{Pb}$	- 0,13
$\text{Fe}^{3+} + 3\text{e}^- \rightleftharpoons \text{Fe}$	- 0,06
$2\text{H}^+ + 2\text{e}^- \rightleftharpoons \text{H}_2(\text{g})$	0,00
$\text{S} + 2\text{H}^+ + 2\text{e}^- \rightleftharpoons \text{H}_2\text{S}(\text{g})$	+ 0,14
$\text{Sn}^{4+} + 2\text{e}^- \rightleftharpoons \text{Sn}^{2+}$	+ 0,15
$\text{Cu}^{2+} + \text{e}^- \rightleftharpoons \text{Cu}^+$	+ 0,16
$\text{SO}_4^{2-} + 4\text{H}^+ + 2\text{e}^- \rightleftharpoons \text{SO}_2(\text{g}) + 2\text{H}_2\text{O}$	+ 0,17
$\text{Cu}^{2+} + 2\text{e}^- \rightleftharpoons \text{Cu}$	+ 0,34
$2\text{H}_2\text{O} + \text{O}_2 + 4\text{e}^- \rightleftharpoons 4\text{OH}^-$	+ 0,40
$\text{SO}_2 + 4\text{H}^+ + 4\text{e}^- \rightleftharpoons \text{S} + 2\text{H}_2\text{O}$	+ 0,45
$\text{Cu}^+ + \text{e}^- \rightleftharpoons \text{Cu}$	+ 0,52
$\text{I}_2 + 2\text{e}^- \rightleftharpoons 2\text{I}^-$	+ 0,54
$\text{O}_2(\text{g}) + 2\text{H}^+ + 2\text{e}^- \rightleftharpoons \text{H}_2\text{O}_2$	+ 0,68
$\text{Fe}^{3+} + \text{e}^- \rightleftharpoons \text{Fe}^{2+}$	+ 0,77
$\text{NO}_3^- + 2\text{H}^+ + \text{e}^- \rightleftharpoons \text{NO}_2(\text{g}) + \text{H}_2\text{O}$	+ 0,80
$\text{Ag}^+ + \text{e}^- \rightleftharpoons \text{Ag}$	+ 0,80
$\text{Hg}^{2+} + 2\text{e}^- \rightleftharpoons \text{Hg}(\ell)$	+ 0,85
$\text{NO}_3^- + 4\text{H}^+ + 3\text{e}^- \rightleftharpoons \text{NO}(\text{g}) + 2\text{H}_2\text{O}$	+ 0,96
$\text{Br}_2(\ell) + 2\text{e}^- \rightleftharpoons 2\text{Br}^-$	+ 1,07
$\text{Pt}^{2+} + 2\text{e}^- \rightleftharpoons \text{Pt}$	+ 1,20
$\text{MnO}_2 + 4\text{H}^+ + 2\text{e}^- \rightleftharpoons \text{Mn}^{2+} + 2\text{H}_2\text{O}$	+ 1,23
$\text{O}_2(\text{g}) + 4\text{H}^+ + 4\text{e}^- \rightleftharpoons 2\text{H}_2\text{O}$	+ 1,23
$\text{Cr}_2\text{O}_7^{2-} + 14\text{H}^+ + 6\text{e}^- \rightleftharpoons 2\text{Cr}^{3+} + 7\text{H}_2\text{O}$	+ 1,33
$\text{Cl}_2(\text{g}) + 2\text{e}^- \rightleftharpoons 2\text{Cl}^-$	+ 1,36
$\text{MnO}_4^- + 8\text{H}^+ + 5\text{e}^- \rightleftharpoons \text{Mn}^{2+} + 4\text{H}_2\text{O}$	+ 1,51
$\text{H}_2\text{O}_2 + 2\text{H}^+ + 2\text{e}^- \rightleftharpoons 2\text{H}_2\text{O}$	+ 1,77
$\text{Co}^{3+} + \text{e}^- \rightleftharpoons \text{Co}^{2+}$	+ 1,81
$\text{F}_2(\text{g}) + 2\text{e}^- \rightleftharpoons 2\text{F}^-$	+ 2,87

Increasing reducing ability/Toenemende reduserende vermoë

